



(12) **United States Design Patent** (10) **Patent No.:** **US D986,084 S**
Jones et al. (45) **Date of Patent:** **** May 16, 2023**

(54) **POLE-MOUNTED SENSOR** 5,244,070 A 9/1993 Carmen et al.
 5,273,151 A 12/1993 Carmen et al.
 (71) Applicant: **IPS Group Inc.**, San Diego, CA (US) 5,426,363 A 6/1995 Akagi et al.
 5,442,348 A 8/1995 Mushell
 (72) Inventors: **David Andrew Jones**, Beecroft (AU); 5,471,139 A 11/1995 Zadoff
David William King, Rancho Santa Fe, 5,614,892 A 3/1997 Ward, II et al.
 CA (US); **Choor Hong Tan**, Eastwood 5,640,002 A 6/1997 Ruppert et al.
 (AU) 5,642,119 A 6/1997 Jacobs
 (Continued)

(73) Assignee: **IPS GROUP INC.**, San Diego, CA (US)
 (**) Term: **15 Years**

FOREIGN PATENT DOCUMENTS

CA 2377010 A1 10/2001
 CA 2363915 A1 5/2003
 (Continued)

(21) Appl. No.: **29/753,722**

OTHER PUBLICATIONS

(22) Filed: **Oct. 1, 2020**
 (51) **LOC (14) Cl.** **10-05**
 (52) **U.S. Cl.**
 USPC **D10/104.1**; D10/42; D10/70; D10/106.6
 (58) **Field of Classification Search**
 USPC D10/42, 46, 70, 104.1, 106.6, 109.1,
 D10/109.2; D14/204, 210, 214–215, 219
 CPC G01S 7/04; G01S 7/4813; G08G 1/017;
 G07F 17/248; H04W 4/44; G06K
 7/10415
 See application file for complete search history.

Co-pending U.S. Appl. No. 16/852,180, inventors King; David William et al., filed Apr. 17, 2020.
 (Continued)

Primary Examiner — Katherine Glennon
 (74) *Attorney, Agent, or Firm* — Wilson Sonsini Goodrich & Rosati

(57) **CLAIM**

The ornamental design for a pole-mounted sensor, as shown and described.

(56) **References Cited**

DESCRIPTION

U.S. PATENT DOCUMENTS

D189,106 S 10/1960 Leiderman
 3,183,411 A 5/1965 Palfi
 3,535,870 A 10/1970 Mitchell et al.
 3,999,372 A 12/1976 Welch et al.
 4,025,791 A 5/1977 Lennington et al.
 4,043,117 A 8/1977 Maresca et al.
 4,310,890 A 1/1982 Trehn et al.
 4,460,965 A 7/1984 Trehn et al.
 4,880,097 A 11/1989 Speas
 D307,875 S * 5/1990 Mallory D10/106.6
 5,201,396 A 4/1993 Chalabian et al.
 5,222,076 A 6/1993 Ng et al.

FIG. 1 is a top, front, right perspective view of a pole-mounted sensor, showing our new design;
FIG. 2 is a front elevational view thereof;
FIG. 3 is a back elevational view thereof;
FIG. 4 is a left side elevational view thereof;
FIG. 5 is a right side elevational view thereof; and,
FIG. 6 is a top plan view thereof.
 The broken lines show portions of the pole-mounted sensor that form no part of the claimed design.

1 Claim, 6 Drawing Sheets

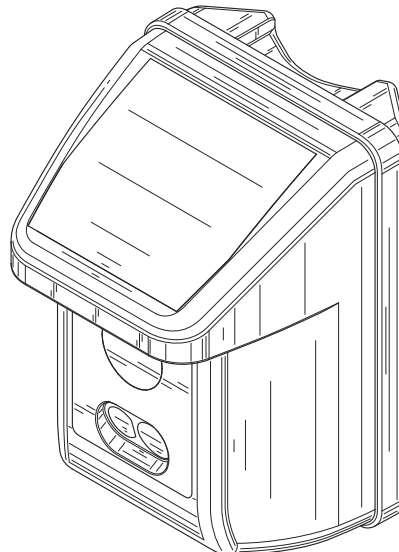

(56)

References Cited

U.S. PATENT DOCUMENTS

5,659,306 A 8/1997 Bahar
 5,710,743 A 1/1998 Dee et al.
 5,777,951 A 7/1998 Mitschele et al.
 5,806,651 A 9/1998 Carmen et al.
 D400,115 S 10/1998 Yaron et al.
 5,842,411 A 12/1998 Johnson
 5,845,268 A 12/1998 Moore
 5,852,411 A 12/1998 Jacobs et al.
 6,078,272 A 6/2000 Jacobs et al.
 6,081,205 A 6/2000 Williams
 6,111,522 A 8/2000 Hiltz et al.
 6,195,015 B1 2/2001 Jacobs et al.
 D439,591 S 3/2001 Reidt et al.
 6,229,455 B1 5/2001 Yost et al.
 D447,714 S 9/2001 Cappiello
 D449,010 S 10/2001 Petrucelli
 6,312,152 B2 11/2001 Dee et al.
 RE37,531 E 1/2002 Chaco et al.
 D454,807 S 3/2002 Cappiello
 D461,728 S 8/2002 Tuxen et al.
 D463,749 S 10/2002 Petrucelli
 6,505,774 B1 1/2003 Fulcher et al.
 6,559,776 B2 5/2003 Katz
 6,697,730 B2 2/2004 Dickerson
 6,812,857 B1 11/2004 Kassab et al.
 6,856,922 B1 2/2005 Austin et al.
 6,885,311 B2 4/2005 Howard et al.
 6,946,974 B1 9/2005 Racunas, Jr.
 7,023,360 B2 4/2006 Staniszewski et al.
 7,029,167 B1 4/2006 Mitschele
 7,391,339 B2 6/2008 Howard et al.
 D575,168 S 8/2008 King et al.
 D587,141 S 2/2009 King et al.
 D600,152 S 9/2009 Stack et al.
 7,783,530 B2 8/2010 Slemmer et al.
 7,825,826 B2 11/2010 Welch et al.
 7,855,661 B2 12/2010 Ponert
 D635,035 S 3/2011 Matsumoto
 D654,816 S 2/2012 MacKay et al.
 D656,046 S 3/2012 MacKay et al.
 8,138,950 B1 3/2012 Leung
 D661,603 S 6/2012 MacKay et al.
 8,279,107 B2 10/2012 Krstanovic et al.
 8,395,532 B2 3/2013 Chauvin et al.
 D692,784 S 11/2013 Anderssen et al.
 8,631,921 B2 1/2014 Jones et al.
 8,684,158 B2 4/2014 Jones et al.
 D705,090 S 5/2014 MacKay et al.
 D707,140 S 6/2014 King et al.
 D707,141 S 6/2014 King et al.
 D707,142 S 6/2014 King et al.
 8,770,371 B2 7/2014 MacKay et al.
 D715,661 S 10/2014 McKaughan et al.
 8,884,785 B2 11/2014 Groft et al.
 D750,513 S 3/2016 King et al.
 9,391,474 B2 * 7/2016 Hunter H02J 7/00302
 9,489,776 B2 11/2016 Kell et al.
 D782,349 S * 3/2017 Konotopskyi D10/70
 D796,355 S 9/2017 Cho et al.
 D801,304 S * 10/2017 Kiafoulis D14/214
 D801,405 S 10/2017 Shih et al.
 D813,838 S * 3/2018 Pietschmann D14/216
 D832,809 S 11/2018 Hardi
 D834,971 S * 12/2018 Ahn D10/70
 D843,973 S 3/2019 Klosowski et al.
 10,299,018 B1 5/2019 King et al.
 D854,430 S * 7/2019 Elrod D10/52
 D858,381 S * 9/2019 Ahn D12/173
 10,491,972 B2 11/2019 King et al.
 D882,426 S * 4/2020 Gross D10/70
 D886,649 S 6/2020 Lan et al.
 10,674,236 B2 6/2020 King et al.
 10,861,334 B2 * 12/2020 Torres G08G 1/14
 D911,857 S * 3/2021 King D10/42
 D927,998 S * 8/2021 Ahn D10/70

D928,639 S * 8/2021 Ahn D10/70
 D930,493 S 9/2021 Katzenelson
 D938,668 S 12/2021 Jia
 D954,571 S * 6/2022 Ahn D10/70
 D960,400 S 8/2022 Ding
 D962,239 S * 8/2022 Arenas de Jesus D14/453
 2002/0008639 A1 1/2002 Dee
 2002/0111768 A1 8/2002 Ghorayeb et al.
 2003/0128136 A1 7/2003 Spier et al.
 2003/0132840 A1 7/2003 Bahar
 2003/0169183 A1 9/2003 Korepanov et al.
 2003/0179107 A1 9/2003 Kibria et al.
 2003/0222792 A1 12/2003 Berman et al.
 2004/0254840 A1 12/2004 Slemmer et al.
 2005/0099320 A1 5/2005 Nath et al.
 2005/0226201 A1 10/2005 McMillin et al.
 2006/0136131 A1 6/2006 Dugan et al.
 2006/0267799 A1 11/2006 Mendelson
 2007/0016539 A1 1/2007 Groft et al.
 2007/0040449 A1 2/2007 Spurlin et al.
 2007/0074702 A1 4/2007 Nakamura et al.
 2007/0184852 A1 8/2007 Johnson et al.
 2007/0189907 A1 8/2007 Kunihiro et al.
 2007/0210935 A1 9/2007 Yost et al.
 2007/0285281 A1 12/2007 Welch
 2008/0052254 A1 2/2008 Al et al.
 2008/0071611 A1 3/2008 Lovett
 2008/0147268 A1 6/2008 Fuller
 2008/0238715 A1 10/2008 Cheng et al.
 2008/0270227 A1 10/2008 Al Amri
 2009/0109062 A1 4/2009 An
 2009/0159674 A1 6/2009 King et al.
 2009/0183966 A1 7/2009 King et al.
 2010/0188932 A1 7/2010 Hanks et al.
 2010/0332394 A1 12/2010 Ioli
 2011/0057815 A1 3/2011 King et al.
 2011/0060653 A1 3/2011 King et al.
 2011/0063133 A1 3/2011 Keller et al.
 2011/0313822 A1 12/2011 Burdick
 2011/0320243 A1 12/2011 Khan
 2012/0084210 A1 4/2012 Farahmand
 2012/0158466 A1 6/2012 John
 2012/0222935 A1 9/2012 MacKay et al.
 2012/0285790 A1 11/2012 Jones et al.
 2012/0285791 A1 11/2012 Jones et al.
 2012/0285792 A1 11/2012 Jones et al.
 2012/0285793 A1 11/2012 Jones et al.
 2012/0286036 A1 11/2012 Jones et al.
 2013/0027218 A1 1/2013 Schwarz et al.
 2013/0099943 A1 4/2013 Subramanya
 2013/0116952 A1 5/2013 Chai
 2014/0108107 A1 4/2014 Jones et al.
 2014/0129158 A1 5/2014 Shea
 2014/0210646 A1 7/2014 Subramanya
 2014/0214499 A1 7/2014 Hudson et al.
 2014/0214500 A1 7/2014 Hudson et al.
 2014/0229246 A1 8/2014 Ghaffari
 2015/0106172 A1 4/2015 Salama
 2017/0098339 A1 4/2017 Keller et al.
 2019/0062914 A1 2/2019 King et al.

FOREIGN PATENT DOCUMENTS

EP 0329129 A2 8/1989
 EP 1128350 B1 10/2007
 IL 149880 A 6/2007
 JP S5259000 A 5/1977
 JP S58121494 A 7/1983
 WO WO-2009154787 A2 12/2009
 WO WO-2014014494 A1 1/2014

OTHER PUBLICATIONS

Co-pending U.S. Appl. No. 29/753,719, inventors Jones; David Andrew et al., filed Oct. 1, 2020.
 Flatley, In San Francisco, Hackers Park for Free. Read filed under Misc. Gadgets, downloaded from www.engadget.com website on May 3, 2010. Originally posted on Jul. 31, 2009 (5 pgs.).

(56)

References Cited

OTHER PUBLICATIONS

Howland. How M2M Maximizes Denver's Revenue. Field TechnologiesOnline.com, Oct. 2011, pp. 9-12 [online] [retrieved Mar. 5, 2013], Retrieved from <http://www.fieldtechnologiesonline.com/doc.mvc/How-M2M-Maximizes-Denvers-Revenue-0001> (4 pgs).
Meter Solutions, Single-Space Meters brochure, downloaded from www.duncansolutions.com website. (revised Apr. 2006) (2 pgs.).
Tung. Design of an advanced on-street parking meter. RIT Scholar Works. Thesis/Dissertation Collections (75 pgs.) (2001).
IPS Group Inc.: Vehicle Detection Sensors, 6 pages [retrieved online Jan. 23, 2023] from Internet URL: <https://ipsgroupinc.com/vehicle-detection-sensors/> (2023).

* cited by examiner

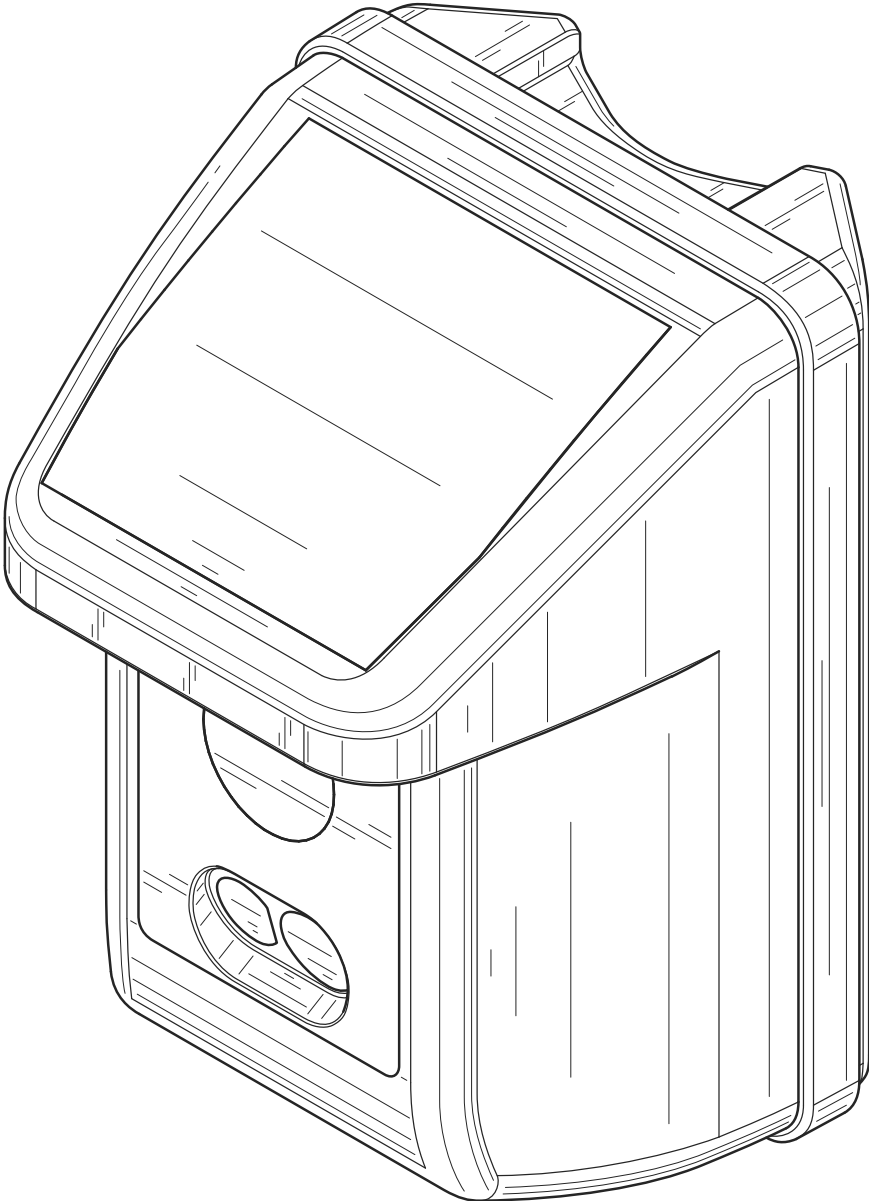

FIG. 1

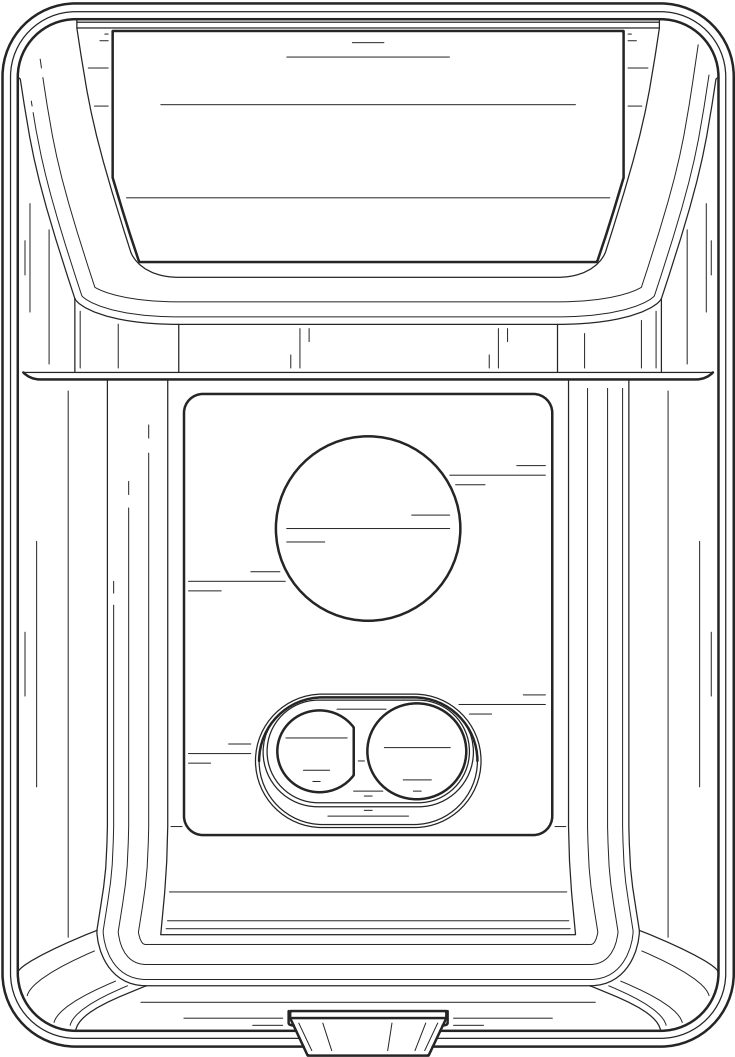

FIG. 2

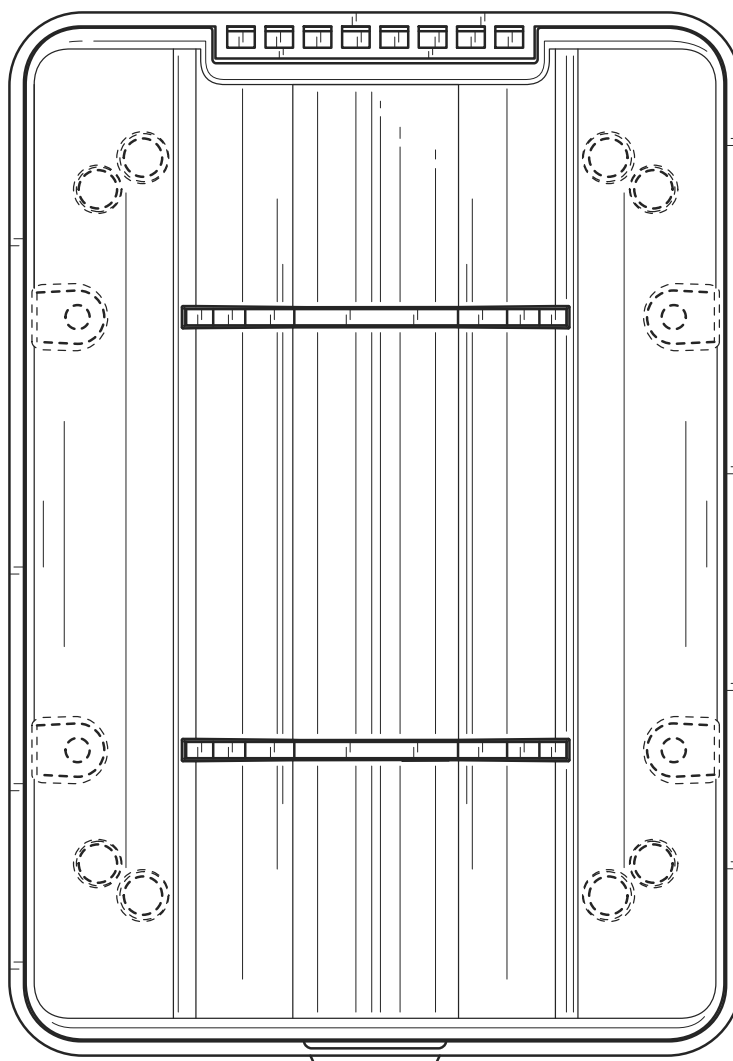

FIG. 3

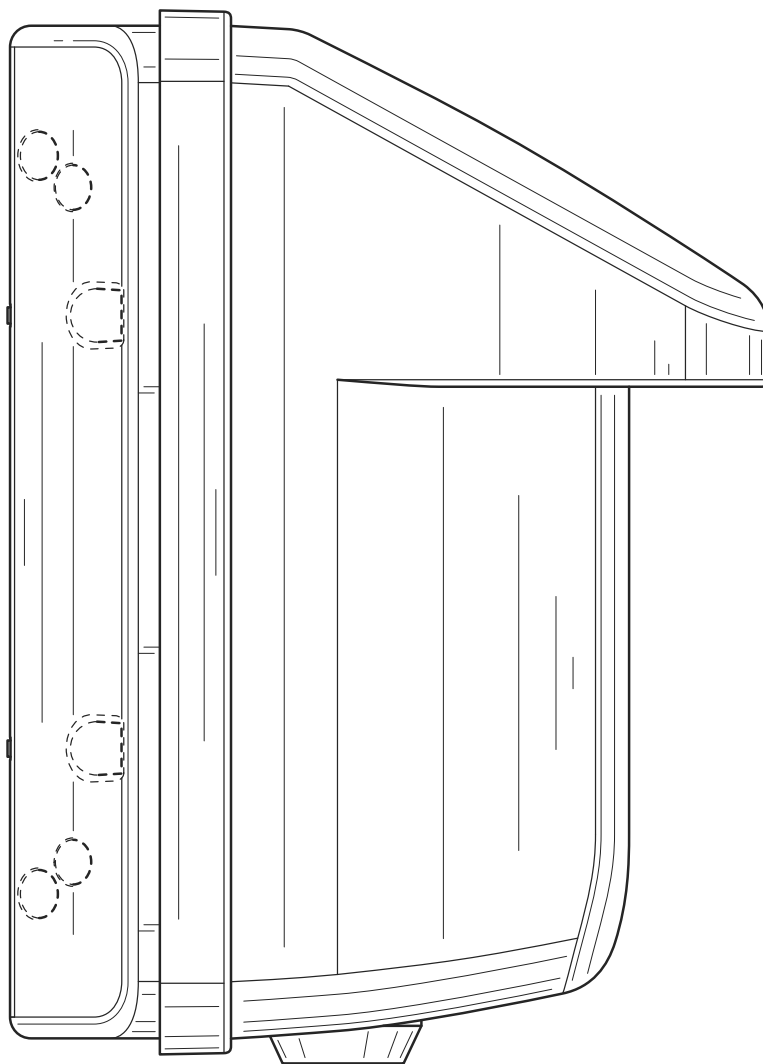

FIG. 4

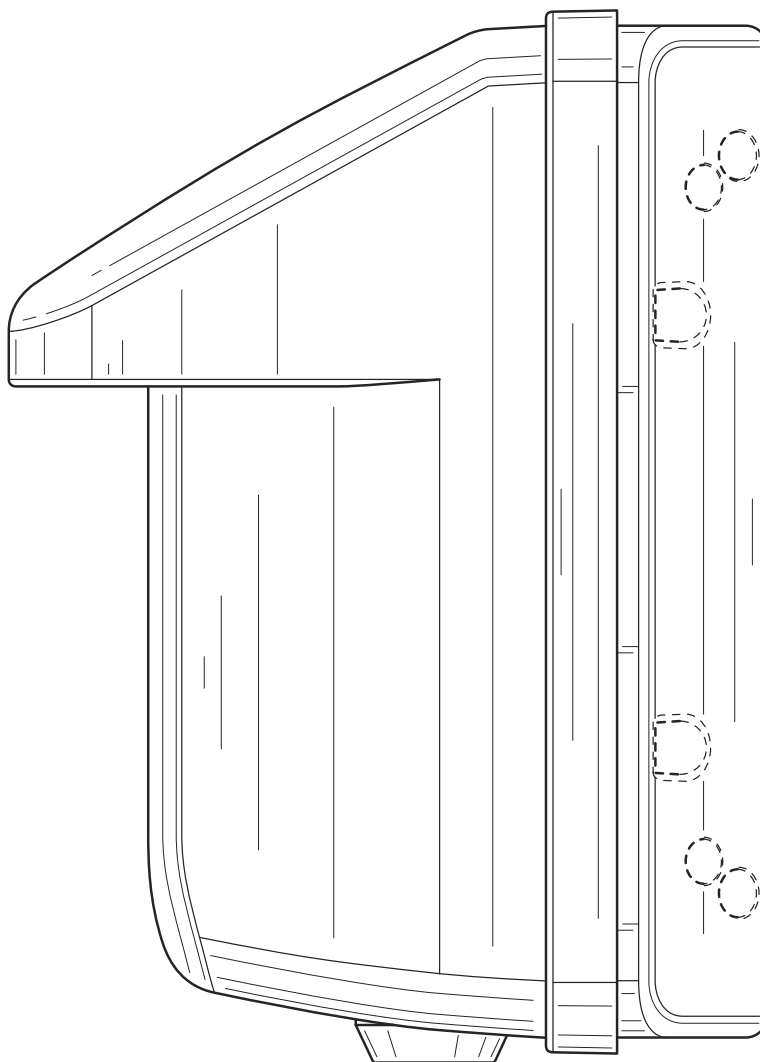

FIG. 5

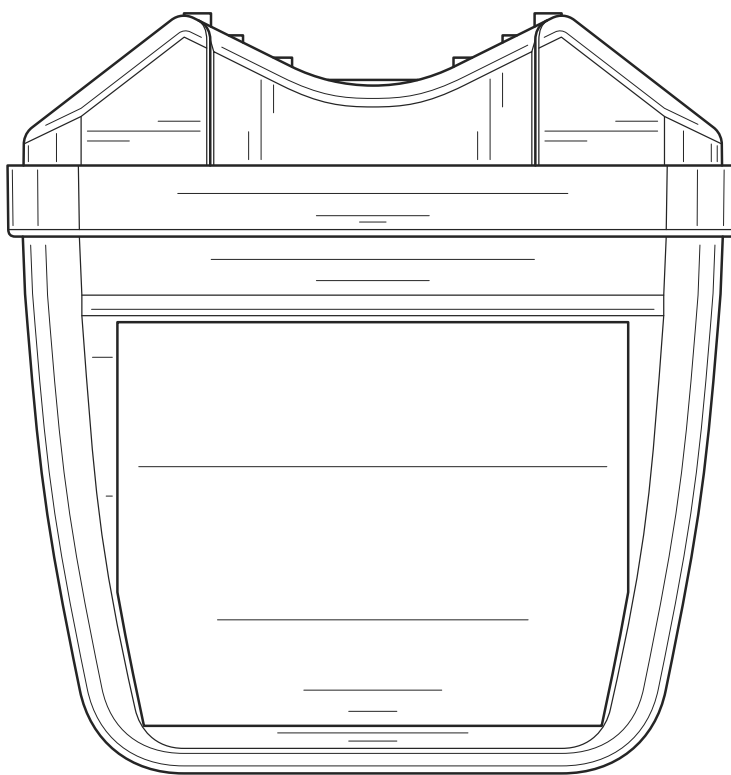

FIG. 6