



(12) **United States Design Patent** (10) **Patent No.:** **US D986,082 S**
Jones et al. (45) **Date of Patent:** **** May 16, 2023**

(54) **SENSOR ENHANCED METER**
 (71) Applicant: **IPS Group Inc.**, San Diego, CA (US)
 (72) Inventors: **David Andrew Jones**, Beecroft (AU);
David William King, Rancho Santa Fe,
 CA (US); **Adam Hugh Gillmore**,
 Wollstonecraft (AU); **Siao Hau Teh**,
 Telopea (AU)
 (73) Assignee: **IPS GROUP INC.**, San Diego, CA
 (US)

D166,753 S 5/1952 Whitney
 2,596,124 A 5/1952 Broussard
 D181,359 S 11/1957 Whitney
 (Continued)

FOREIGN PATENT DOCUMENTS

CA 2377010 A1 10/2001
 CA 2363915 A1 5/2003
 (Continued)

OTHER PUBLICATIONS

IPS Group, Stereoscopic Sensors, Vehicle detection, Date first available Jul. 12, 2022, [online]retrieved Nov. 30, 2022,available from <https://ipsgroupinc.com/wp-content/uploads/2022/07/Vehicle-Detection-Smart-Sensors.pdf> (Year: 2022).*
 (Continued)

(**) Term: **15 Years**
 (21) Appl. No.: **29/759,012**
 (22) Filed: **Nov. 19, 2020**
 (51) **LOC (14) Cl.** **10-03**
 (52) **U.S. Cl.**
 USPC **D10/42**; D10/103
 (58) **Field of Classification Search**
 USPC D10/40-42, 46, 49, 103; D13/162,
 D13/162.1, 164, 177; D99/28
 CPC .. G06Q 20/3278; G06Q 20/352; G06Q 20/18;
 G07B 15/00; G07B 15/02; G06K
 7/10316; G06K 7/0004; G06K 19/0704;
 G07F 17/248; G07F 17/00; G07F 15/248;
 Y10T 29/49826; Y04S 50/12; H04Q
 2209/886
 See application file for complete search history.

Primary Examiner — Keli L Hill
Assistant Examiner — Sara S Sahneh
 (74) *Attorney, Agent, or Firm* — Wilson Sonsini Goodrich
 & Rosati

CLAIM

(57) The ornamental design for a sensor enhanced meter, as shown and described.

DESCRIPTION

FIG. 1 is a top, back, left perspective view of a sensor enhanced meter, showing our new design;
 FIG. 2 is a top, front, right perspective view thereof;
 FIG. 3 is a front elevational view thereof;
 FIG. 4 is a back elevational view thereof;
 FIG. 5 is a left side elevational view thereof;
 FIG. 6 is a right side elevational view thereof; and,
 FIG. 7 is a top plan view thereof.
 The broken lines shown are included for the purpose of illustrating portions of the sensor enhanced meter that form no part of the claim.

1 Claim, 7 Drawing Sheets

(56) **References Cited**
 U.S. PATENT DOCUMENTS
 D98,810 S 3/1936 Carl
 D107,577 S 12/1937 McGay et al.
 2,161,046 A 6/1939 Hitzeman
 D116,805 S 9/1939 Ben
 2,229,183 A 1/1941 Mitchell
 D162,698 S 3/1951 James
 D166,059 S 2/1952 Adolph et al.

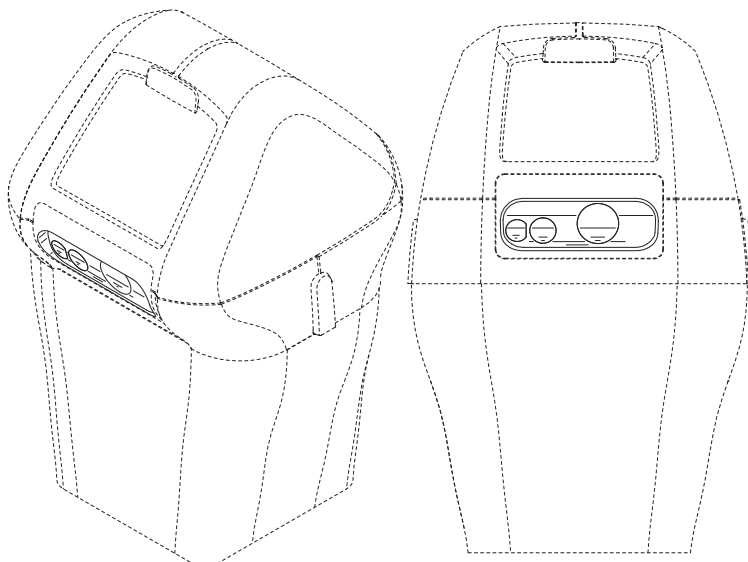

(56)

References Cited

U.S. PATENT DOCUMENTS

2,822,682	A	2/1958	Sollenberger	D454,807	S	3/2002	Cappiello	
2,832,506	A	4/1958	Hatcher	6,373,422	B1	4/2002	Mostafa	
D189,106	S	10/1960	Leiderman	6,373,442	B1	4/2002	Thomas et al.	
2,988,191	A	6/1961	Grant	D461,728	S	8/2002	Tuxen et al.	
D199,270	S	9/1964	Frank	6,456,491	B1	9/2002	Flannery et al.	
D200,216	S	2/1965	Broussard	D463,749	S	10/2002	Petrucelli	
3,183,411	A	5/1965	Palfi	6,457,586	B2	10/2002	Yasuda et al.	
3,486,324	A	12/1969	Carl-Axel	6,505,774	B1	1/2003	Fulcher et al.	
3,535,870	A	10/1970	Mitchell et al.	6,559,776	B2	5/2003	Katz	
3,721,463	A	3/1973	Attwood et al.	6,697,730	B2	2/2004	Dickerson	
3,999,372	A	12/1976	Welch et al.	6,747,575	B2	6/2004	Chauvin et al.	
4,025,791	A	5/1977	Lennington et al.	D498,795	S	11/2004	Nunn	
4,031,991	A	6/1977	Malott	6,812,857	B1	11/2004	Kassab et al.	
4,043,117	A	8/1977	Maresca et al.	6,856,922	B1	2/2005	Austin et al.	
4,310,890	A	1/1982	Trehn et al.	6,874,340	B1	4/2005	Berman	
4,460,965	A	7/1984	Trehn et al.	6,885,311	B2	4/2005	Howard et al.	
4,812,805	A	3/1989	Lachat et al.	6,889,899	B2	5/2005	Silberberg	
4,823,928	A	4/1989	Speas	D506,509	S	6/2005	Nunn	
4,825,425	A	4/1989	Turner	6,914,411	B2	7/2005	Couch et al.	
4,875,598	A	10/1989	Dahl	6,929,179	B2	8/2005	Fulcher et al.	
4,880,097	A	11/1989	Speas	6,946,974	B1	9/2005	Racunas, Jr.	
4,895,238	A	1/1990	Speas	7,019,420	B2	3/2006	Kogan et al.	
D319,077	S	8/1991	Arato et al.	7,019,670	B2	3/2006	Bahar	
5,065,156	A	11/1991	Bernier	7,023,360	B2	4/2006	Staniszewski et al.	
5,155,614	A	10/1992	Carmen et al.	7,027,773	B1	4/2006	McMillin	
5,201,396	A	4/1993	Chalabian et al.	7,029,167	B1	4/2006	Mitschele	
5,222,076	A	6/1993	Ng et al.	7,183,999	B2	2/2007	Matthews et al.	
5,244,070	A	9/1993	Carmen et al.	D543,588	S	5/2007	Herbert et al.	
5,273,151	A	12/1993	Carmen et al.	7,222,031	B2	5/2007	Heatley	
5,360,095	A	11/1994	Speas	7,237,716	B2	7/2007	Silberberg	
5,426,363	A	6/1995	Akagi et al.	7,388,349	B2	6/2008	Elder et al.	
5,442,348	A	8/1995	Mushell	7,391,339	B2	6/2008	Howard et al.	
5,471,139	A	11/1995	Zadoff	D575,168	S	8/2008	King et al.	
5,563,491	A	10/1996	Tseng	D587,141	S	2/2009	King et al.	
5,614,892	A	3/1997	Ward, II et al.	7,748,620	B2	7/2010	Gomez et al.	
5,617,942	A	4/1997	Ward, II et al.	7,772,720	B2	8/2010	McGee et al.	
5,640,002	A	6/1997	Ruppert et al.	7,783,530	B2	8/2010	Slemmer et al.	
5,642,119	A	6/1997	Jacobs	7,825,826	B2	11/2010	Welch et al.	
5,648,906	A	7/1997	Amirpanahi	7,854,310	B2	12/2010	King et al.	
5,659,306	A	8/1997	Bahar	7,855,661	B2	12/2010	Ponert	
D388,231	S	12/1997	Magee et al.	D635,035	S	3/2011	Matsumoto	
5,710,743	A	1/1998	Dee et al.	7,933,841	B2	4/2011	Schmeyer et al.	
5,732,812	A	3/1998	Grainger et al.	D654,816	S	2/2012	MacKay et al.	
D393,212	S	4/1998	Lucas	D656,046	S	3/2012	MacKay et al.	
5,737,710	A	4/1998	Anthonyson	8,138,950	B1	3/2012	Leung	
5,777,951	A	7/1998	Mitschele et al.	D661,603	S	6/2012	MacKay et al.	
5,778,067	A	7/1998	Jones et al.	D661,608	S	6/2012	Kimmich	
5,805,083	A	9/1998	Sutton et al.	8,279,107	B2	10/2012	Krstanovic et al.	
5,806,651	A	9/1998	Carmen et al.	8,325,057	B2	12/2012	Salter	
D400,115	S	10/1998	Yaron et al.	8,395,532	B2	3/2013	Chauvin et al.	
5,833,042	A	11/1998	Baitch et al.	D683,794	S	6/2013	Randall	
5,841,369	A	11/1998	Sutton et al.	D690,771	S	10/2013	Randall	
5,842,411	A	12/1998	Johnson	D692,784	S	11/2013	Anderssen et al.	
5,845,268	A	12/1998	Moore	8,590,687	B2	11/2013	King et al.	
5,852,411	A	12/1998	Jacobs et al.	8,595,054	B2	11/2013	King et al.	
D412,289	S	7/1999	Winwood	8,631,921	B2	1/2014	Jones et al.	
5,954,182	A	9/1999	Wei	8,684,158	B2	4/2014	Jones et al.	
5,966,345	A	10/1999	Dee et al.	D705,090	S	5/2014	MacKay et al.	
6,037,880	A	3/2000	Manion	D707,140	S	6/2014	King et al.	
6,078,272	A	6/2000	Jacobs et al.	D707,141	S	6/2014	King et al.	
6,081,205	A	6/2000	Williams	D707,142	S	6/2014	King et al.	
6,109,418	A	8/2000	Yost	8,770,371	B2	7/2014	MacKay et al.	
6,111,522	A	8/2000	Hiltz et al.	D716,157	S	10/2014	MacKay et al.	
6,116,403	A	9/2000	Kiehl	8,862,494	B2	10/2014	King et al.	
6,195,015	B1	2/2001	Jacobs et al.	8,884,785	B2	11/2014	Groft et al.	
D439,591	S	3/2001	Reidt et al.	9,127,964	B2	9/2015	Schwarz et al.	
RE37,193	E	5/2001	Ward et al.	9,169,626	B2	10/2015	Guler et al.	
6,229,455	B1	5/2001	Yost et al.	D749,000	S	2/2016	King et al.	
6,230,868	B1	5/2001	Tuxen et al.	D755,650	S	5/2016	King et al.	
6,243,028	B1	6/2001	Krygler et al.	D756,807	S	5/2016	King et al.	
D447,714	S	9/2001	Cappiello	D756,808	S	5/2016	King et al.	
D449,010	S	10/2001	Petrucelli	D762,040	S	7/2016	King	D99/28
6,309,098	B1	10/2001	Wong	9,489,776	B2	11/2016	Kell et al.	
6,312,152	B2	11/2001	Dee et al.	9,508,198	B1	11/2016	King et al.	
RE37,531	E	1/2002	Chaco et al.	9,652,921	B2	5/2017	MacKay et al.	
				9,661,403	B2	5/2017	King et al.	
				D799,992	S	10/2017	Ehara	
				9,805,518	B2	10/2017	King et al.	
				D802,875	S	11/2017	King	D99/28

(56)

References Cited

U.S. PATENT DOCUMENTS

- 10,299,018 B1 5/2019 King et al.
D851,605 S 6/2019 Maetani et al.
D853,678 S * 7/2019 King D99/43
D911,857 S * 3/2021 King D10/42
11,100,824 B2 8/2021 King et al.
D955,231 S * 6/2022 King D99/28
D959,298 S * 8/2022 Jones D10/97
D959,299 S * 8/2022 Jones D10/97
D959,997 S * 8/2022 Jones D10/97
D971,033 S * 11/2022 King D99/28
2001/0012241 A1 8/2001 Dee et al.
2001/0047278 A1 11/2001 Brookner et al.
2001/0051531 A1 12/2001 Singhal et al.
2002/0008639 A1 1/2002 Dee
2002/0111768 A1 8/2002 Ghorayeb et al.
2003/0092387 A1 5/2003 Hjelmvik
2003/0112151 A1 6/2003 Chauvin et al.
2003/0112597 A1 6/2003 Smith
2003/0121754 A1 7/2003 King
2003/0128010 A1 7/2003 Hsu
2003/0128136 A1 7/2003 Spier et al.
2003/0132840 A1 7/2003 Bahar
2003/0140531 A1 7/2003 Pippins
2003/0144972 A1 7/2003 Cordery et al.
2003/0169183 A1 9/2003 Korepanov et al.
2003/0179107 A1 9/2003 Kibria et al.
2003/0220835 A1 11/2003 Barnes et al.
2003/0222792 A1 12/2003 Berman et al.
2004/0068434 A1 4/2004 Kanekon
2004/0084278 A1 5/2004 Harris et al.
2004/0094619 A1 5/2004 Silberberg
2004/0181496 A1 9/2004 Odinotski et al.
2004/0254840 A1 12/2004 Slemmer et al.
2004/0264302 A1 12/2004 Ward
2005/0040951 A1 2/2005 Zalewski et al.
2005/0099320 A1 5/2005 Nath et al.
2005/0155839 A1 7/2005 Banks et al.
2005/0178639 A1 8/2005 Brumfield et al.
2005/0192911 A1 9/2005 Mattern
2005/0226201 A1 10/2005 McMillin et al.
2006/0021848 A1 2/2006 Smith
2006/0116972 A1 6/2006 Wong
2006/0136131 A1 6/2006 Dugan et al.
2006/0149684 A1 7/2006 Matsuura et al.
2006/0152349 A1 7/2006 Ratnakar
2006/0267799 A1 11/2006 Mendelson
2007/0016539 A1 1/2007 Groft et al.
2007/0040449 A1 2/2007 Spurlin et al.
2007/0074702 A1 4/2007 Nakamura et al.
2007/0094153 A1 4/2007 Ferraro
2007/0114849 A1 5/2007 Falik et al.
2007/0119682 A1 5/2007 Banks et al.
2007/0136128 A1 6/2007 Janacek et al.
2007/0184852 A1 8/2007 Johnson et al.
2007/0189907 A1 8/2007 Kunihiro et al.
2007/0210935 A1 9/2007 Yost et al.
2007/0285281 A1 12/2007 Welch
2008/0052254 A1 2/2008 Al et al.
2008/0071611 A1 3/2008 Lovett
2008/0093454 A1 4/2008 Yamazaki et al.
2008/0147268 A1 6/2008 Fuller
2008/0208680 A1 8/2008 Cho
2008/0238715 A1 10/2008 Cheng et al.
2008/0245638 A1 10/2008 King et al.
2008/0270227 A1 10/2008 Al Amri
2009/0026842 A1 1/2009 Hunter et al.
2009/0032368 A1 2/2009 Hunter et al.
2009/0095593 A1 4/2009 King et al.
2009/0109062 A1 4/2009 An
2009/0159674 A1 6/2009 King et al.
2009/0183966 A1 7/2009 King et al.
2009/0192950 A1 7/2009 King et al.
2009/0267732 A1 10/2009 Chauvin et al.
2009/0284907 A1 11/2009 Regimbal et al.
2009/0315720 A1 12/2009 Clement et al.
2010/0106517 A1 4/2010 Kociubinski et al.
2010/0188932 A1 7/2010 Hanks et al.
2010/0332394 A1 12/2010 Ioli
2011/0057815 A1 3/2011 King et al.
2011/0060653 A1 3/2011 King et al.
2011/0063133 A1 3/2011 Keller et al.
2011/0203901 A1 8/2011 King et al.
2011/0313822 A1 12/2011 Burdick
2011/0320243 A1 12/2011 Khan
2012/0084210 A1 4/2012 Farahmand
2012/0158466 A1 6/2012 John
2012/0222935 A1 9/2012 MacKay et al.
2012/0285790 A1 11/2012 Jones et al.
2012/0285791 A1 11/2012 Jones et al.
2012/0285792 A1 11/2012 Jones et al.
2012/0285793 A1 11/2012 Jones et al.
2012/0286036 A1 11/2012 Jones et al.
2012/0292385 A1 11/2012 MacKay et al.
2013/0005445 A1 1/2013 Walker et al.
2013/0027218 A1 1/2013 Schwarz et al.
2013/0099943 A1 4/2013 Subramanya
2013/0116952 A1 5/2013 Chai
2013/0238406 A1 9/2013 King et al.
2014/0108107 A1 4/2014 Jones et al.
2014/0129158 A1 5/2014 Shea
2014/0174881 A1 6/2014 King et al.
2014/0210646 A1 7/2014 Subramanya
2014/0214499 A1 7/2014 Hudson et al.
2014/0214500 A1 7/2014 Hudson et al.
2014/0229246 A1 8/2014 Ghaffari
2015/0106172 A1 4/2015 Salama
2015/0129391 A1 5/2015 Jones et al.
2015/0332587 A1 11/2015 Schwarz et al.
2017/0098339 A1 4/2017 Keller et al.
2018/0025549 A1 1/2018 King et al.
2018/0225909 A1 8/2018 MacKay et al.
2019/0073837 A1 * 3/2019 Oliver G07F 17/248
2019/0131819 A1 5/2019 Bell

FOREIGN PATENT DOCUMENTS

- CA 142346 * 9/2011
CA 145137 * 4/2012
CN 305987969 * 8/2019
EP 0329129 A2 8/1989
EP 0980055 B1 9/2001
EP 1128350 B1 10/2007
FR 2837583 A1 9/2003
IL 149880 A 6/2007
JP S5259000 A 5/1977
JP S58121494 A 7/1983
JP 2002042181 A 2/2002
JP 2002099640 A 4/2002
JP 2005267430 A 9/2005
KR 20050038077 A 4/2005
MY 12-1360-0101-0001 * 10/2012
WO WO-2005031494 A2 4/2005
WO WO-2006095352 A2 9/2006
WO WO-2009154787 A2 12/2009
WO WO-2014014494 A1 1/2014

OTHER PUBLICATIONS

- IPS Group, Single-Space, M5 Single-Space meter, Date first available Jul. 12, 2022, [online]retrieved Nov. 30, 2022,available from <https://ipsgroupinc.com/wp-content/uploads/2022/07/M5-Single-Space-Smart-Meter>. (Year: 2022).*
- Cell Net Data Systems. First Wireless Monitoring of Parking Meters Results in Theft Arrests Using CellNet Data Systems Technology. PRNewswire (May 11, 1999) (2 pgs.).
- City of Culver City. CA Agenda Item Report. Approval of a Contract with IPS Group Inc., for the Sole-Source Purchase of 1,000 Parking Meters. (3 pgs.) (Dec. 12, 2011).
- Co-pending U.S. Appl. No. 29/680,837, inventors King; David William et al., filed Feb. 20, 2019.
- Co-pending U.S. Appl. No. 29/759,014, inventors Jones; David Andrew et al., filed Nov. 19, 2020.

(56)

References Cited

OTHER PUBLICATIONS

Co-pending U.S. Appl. No. 29/759,016, inventors Jones; David Andrew et al., filed Nov. 19, 2020.

Co-pending U.S. Appl. No. 29/759,017, inventors Jones; David Andrew et al., filed Nov. 19, 2020.

Co-pending U.S. Appl. No. 29/759,019, inventors Jones; David Andrew et al., filed Nov. 19, 2020.

Fidelman. Time's Running Out for Parking Meters at Present Locations: \$270,000 Cited as Replacement Cost. City Employees Who Ticket Motorists Find Electronic Meters Unsuitable. The Gazette, Final Edition, Montreal, Quebec, Canada, Nov. 12, 2002, p. A7.

Flatley. In San Francisco, Hackers Park for Free. Read filed under Misc. Gadgets, downloaded from www.engadget.com website on May 3, 2010. Originally posted on Jul. 31, 2009 (5 pgs.).

Howland. How M2M Maximizes Denver's Revenue. Field TechnologiesOnline.com, Oct. 2011, pp. 9-12 [online] [retrieved Mar. 5, 2013], Retrieved from <http://www.fieldtechnologiesonline.com/doc.mvc/How-M2M-Maximizes-Denvers-Revenue-0001> (4 pgs).

Jim Bonfield. An Excerise in Changing The Business: Advertising Vending Machines. (4 pgs.) (Feb. 7, 2018).

Meter Solutions, Single-Space Meters brochure, downloaded from www.duncansolutions.com website. (revised Apr. 2006) (2 pgs.).

Sedadi. Card & Coin Parking Meter Lease. City of Los Angeles Inter-Departmental Correspondence. (4 pgs.) (Nov. 29, 2010).

Spyker et al. Predicting Capacitor Run Time For a Battery/Capacitor Hybrid Source. Power Electronic Drives and Energy Systems for Industrial Growth. 1998. Proceedings. 1998 IEEE International Conference, pp. 809-814.

The U.S. Conference of Mayors Presents 'Best Practice' Awards, Los Angeles, New Orleans, Elizabeth, N.J. and Long Beach, CA Honored for Excellence & Innovation in Public-Private partnerships, Press Release Jan. 20, 2012 (3 pgs.).

Transportation Commission Staff Report. Alternate Downtown Parking Pay Technology. Agenda Item No. 5.b (4 pgs.) (Oct. 20, 2011).

Tung. Design of an advanced on-street parking meter. RIT Scholar Works. Thesis/Dissertation Collections (75 pgs.) (2001).

* cited by examiner

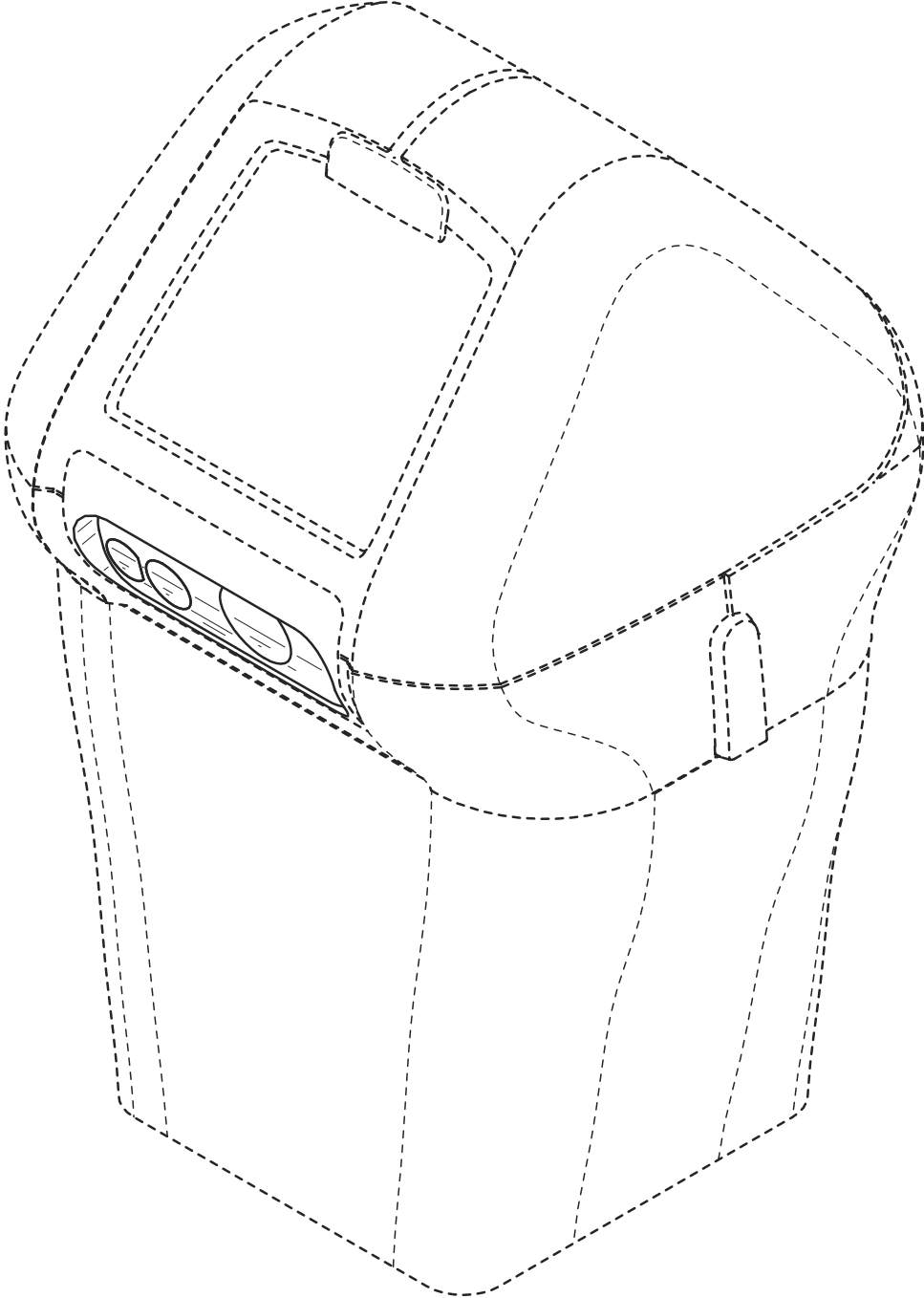

FIG. 1

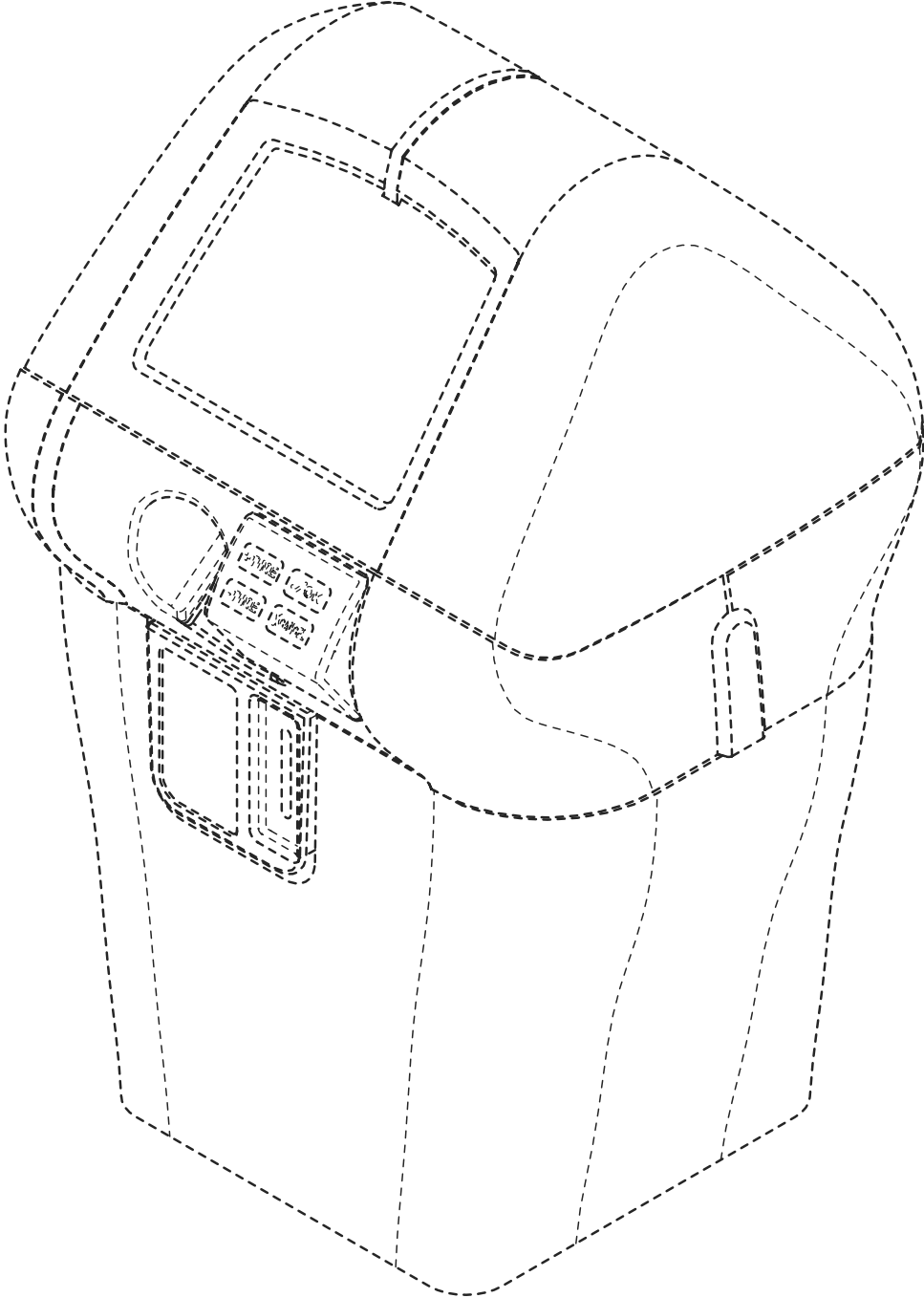

FIG. 2

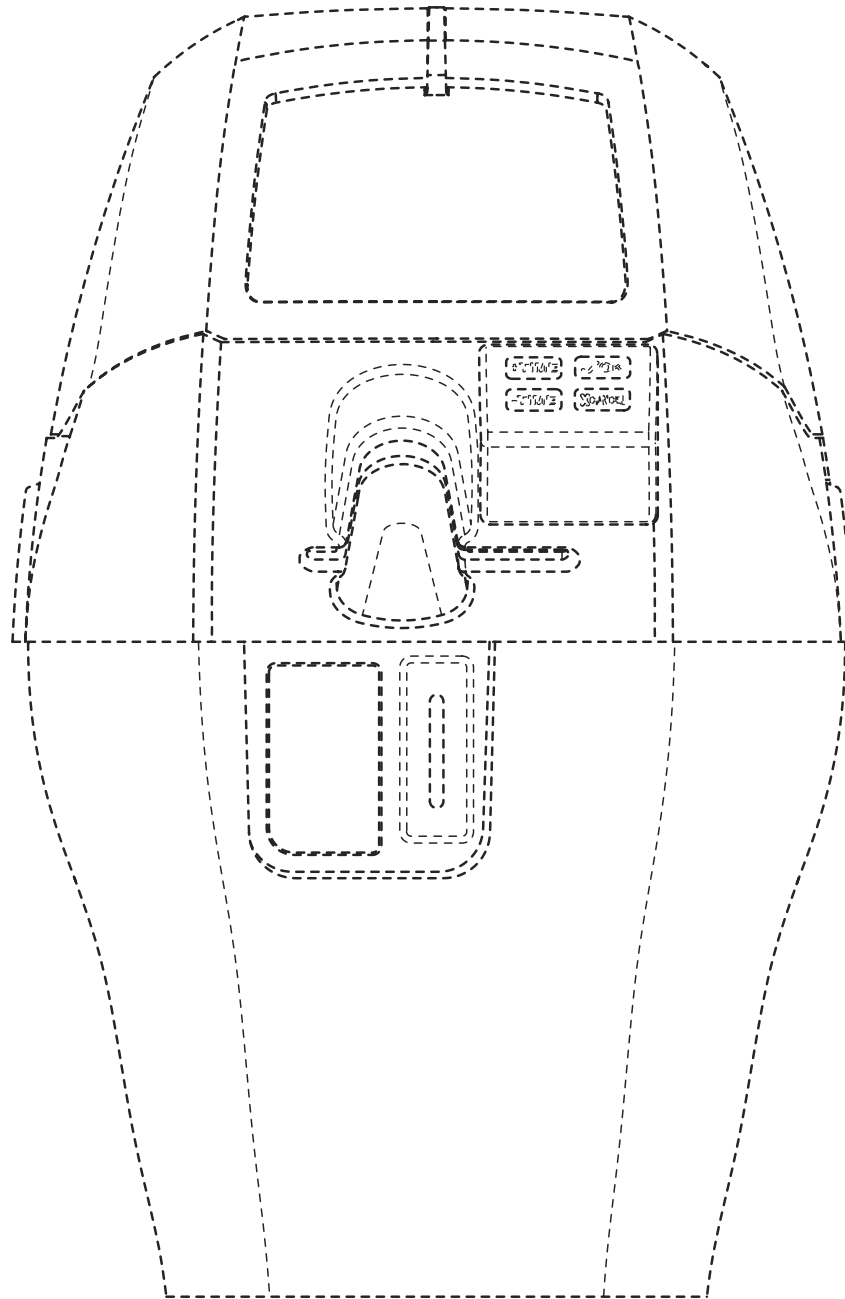

FIG. 3

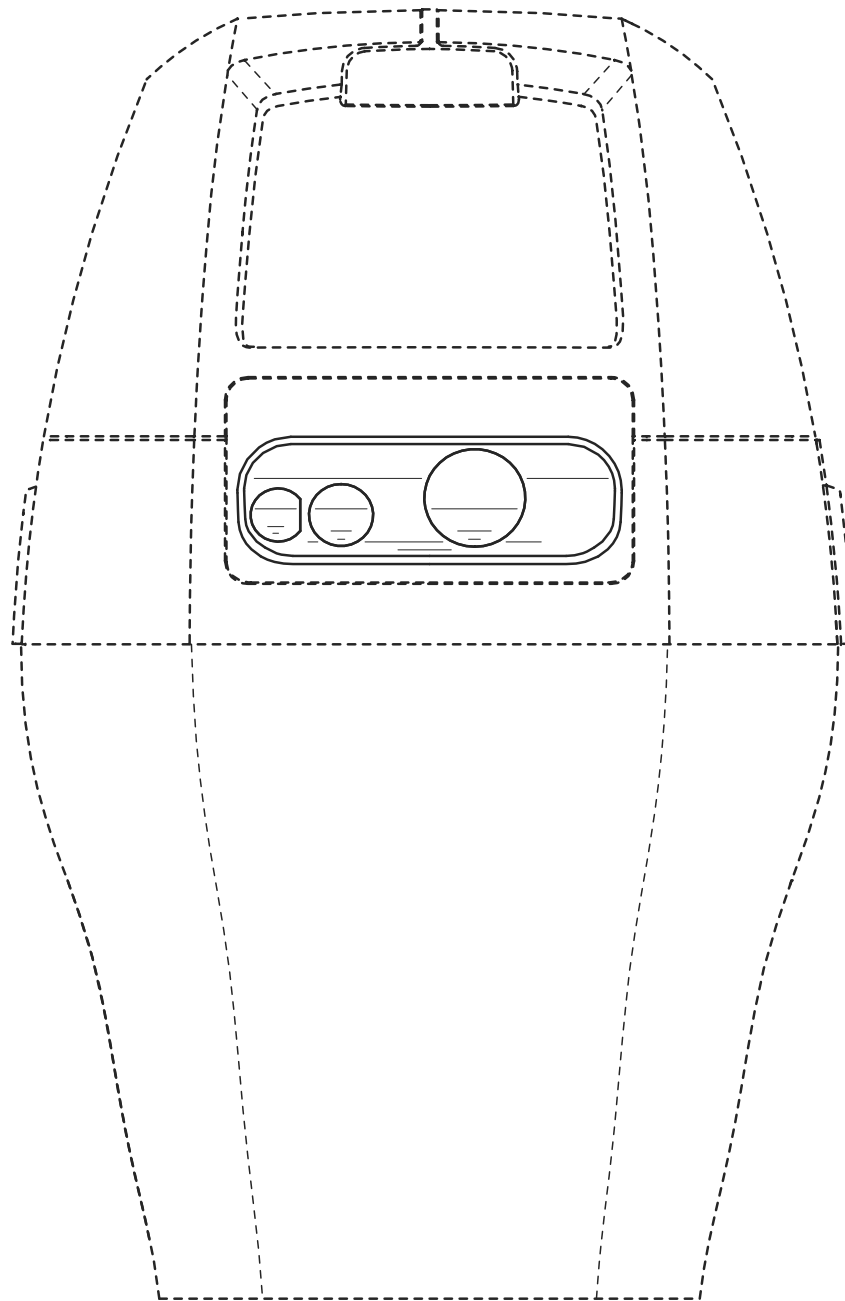

FIG. 4

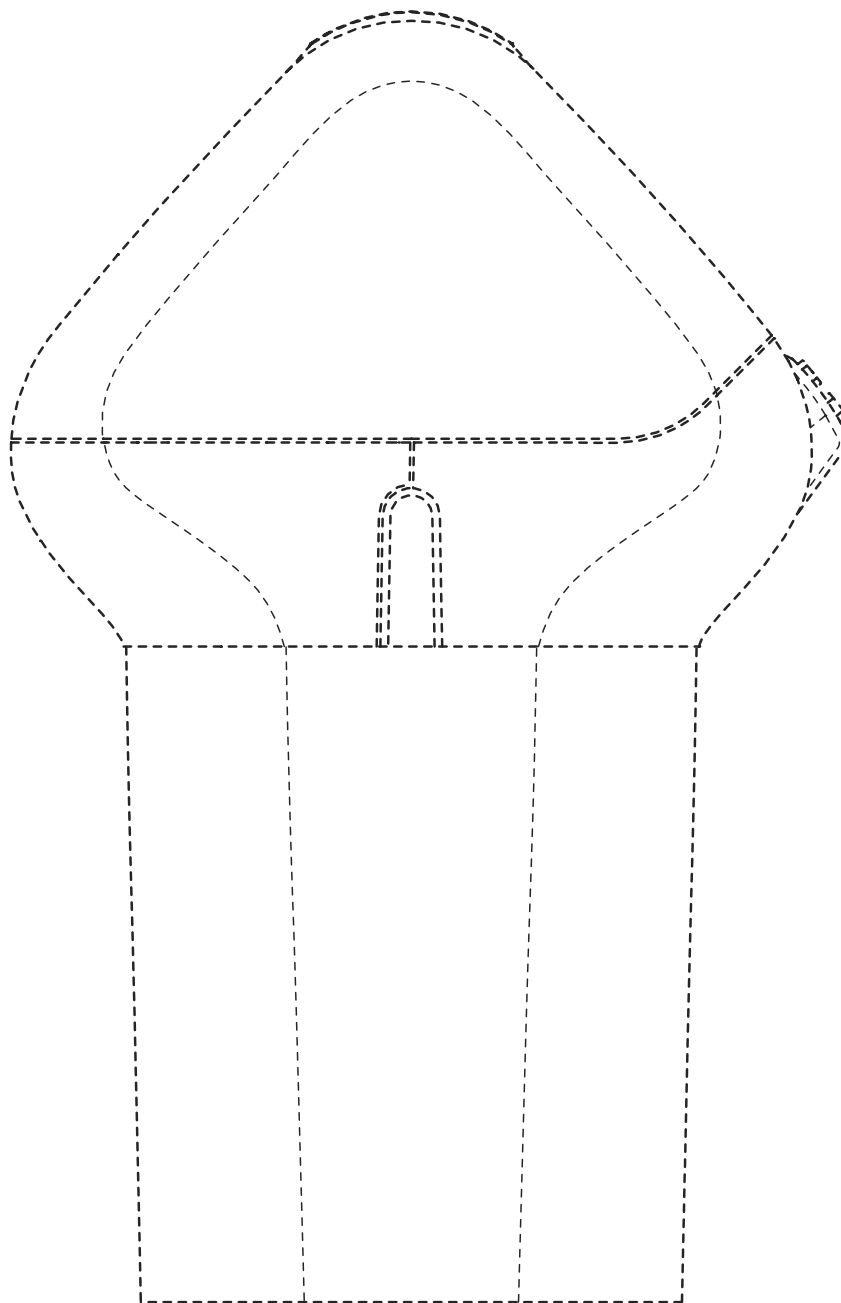

FIG. 5

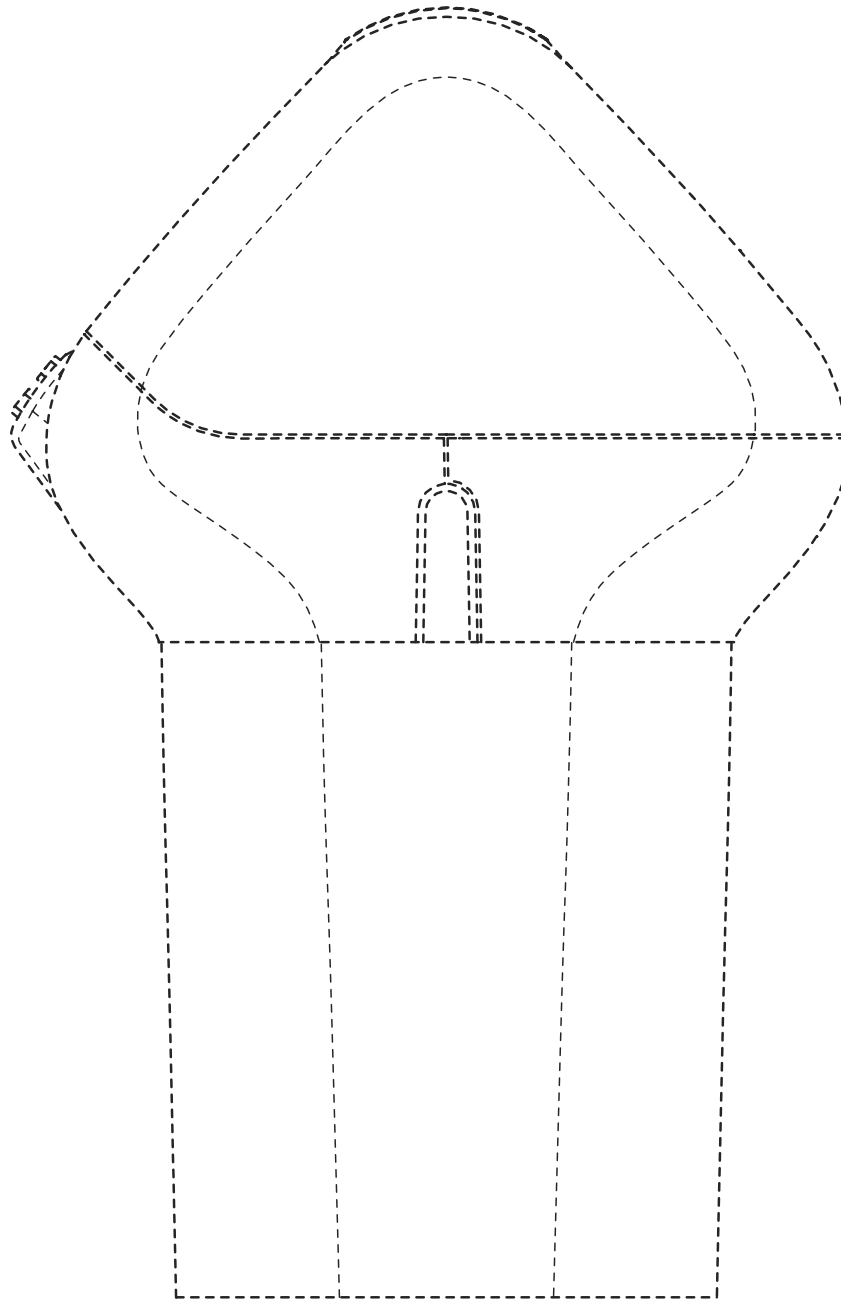

FIG. 6

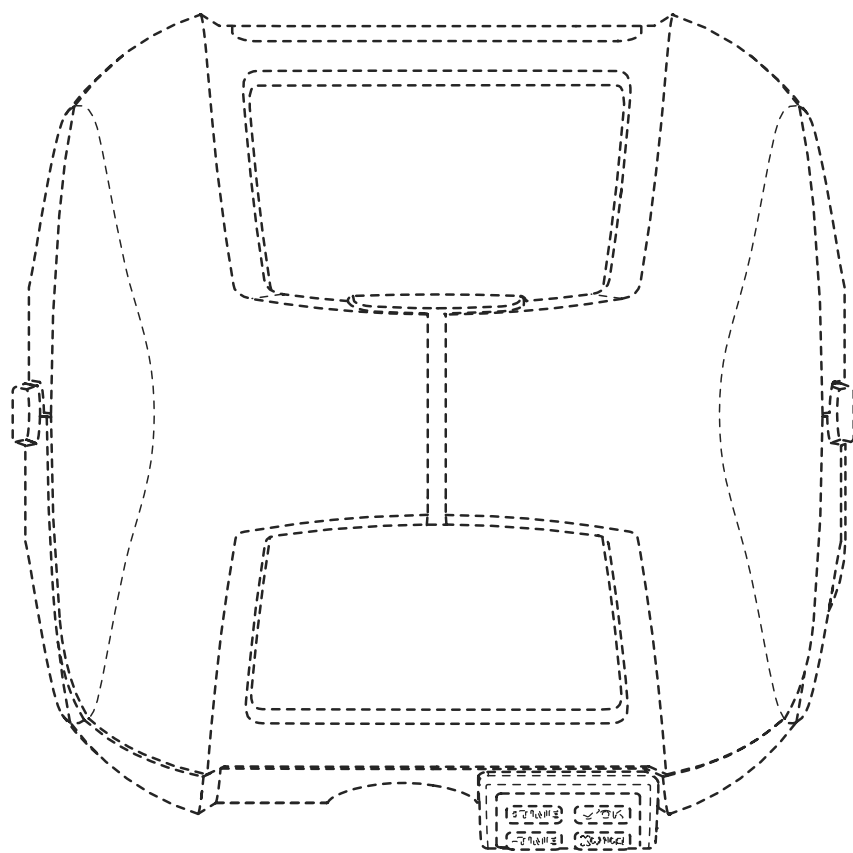

FIG. 7