



(12) **United States Design Patent**  
**Jones et al.**

(10) **Patent No.:** **US D959,299 S**  
(45) **Date of Patent:** **\*\* Aug. 2, 2022**

(54) **METER COVER**

H05K 7/005; H05K 7/02; G01D 11/24;  
G01D 11/245; G01D 11/26; G01D 11/28  
See application file for complete search history.

(71) Applicant: **IPS Group Inc.**, San Diego, CA (US)

(72) Inventors: **David Andrew Jones**, Beecroft (AU);  
**David William King**, Rancho Santa Fe,  
CA (US); **Adam Hugh Gillmore**,  
Wollstonecraft (AU)

(73) Assignee: **IPS GROUP INC.**, San Diego, CA  
(US)

(\*\*) Term: **15 Years**

(21) Appl. No.: **29/759,017**

(22) Filed: **Nov. 19, 2020**

(51) **LOC (13) Cl.** ..... **10-03**

(52) **U.S. Cl.**

USPC ..... **D10/42**; D10/97; D10/100; D10/102

(58) **Field of Classification Search**

USPC ..... D10/40, 42, 97, 99, 100, 102

CPC . G07B 15/02; G07C 1/30; H04Q 9/00; H04Q

9/02; H04Q 2209/43; H04Q 2209/47;

H04Q 2209/80; H04Q 2209/886; H05K

5/00; H05K 5/0004; H05K 5/0008; H05K

5/0013; H05K 5/0017; H05K 5/0021;

H05K 5/0026; H05K 5/003; H05K

5/0034; H05K 5/0039; H05K 5/0043;

H05K 5/0047; H05K 5/0052; H05K

5/0056; H05K 5/006; H05K 5/0065;

H05K 5/0069; H05K 5/0073; H05K

5/0078; H05K 5/0082; H05K 5/0086;

H05K 5/0091; H05K 5/0095; H05K 5/03;

H05K 5/04; H05K 5/06; H05K 5/061;

H05K 5/062; H05K 5/063; H05K 5/064;

H05K 5/065; H05K 5/066; H05K 5/067;

H05K 5/068; H05K 5/069; H05K 7/00;

(56) **References Cited**

U.S. PATENT DOCUMENTS

D98,810 S	3/1936	Magee
D107,577 S	12/1937	McGay et al.
2,161,046 A	6/1939	Hitzeman
D116,805 S	9/1939	Reznek
2,229,183 A	1/1941	Mitchell
D162,698 S	3/1951	Teague
D166,059 S	2/1952	Yoss et al.
D166,753 S	5/1952	Jones
2,596,124 A	5/1952	Broussard
D181,359 S	11/1957	Jones
2,822,682 A	2/1958	Sollenberger
2,832,506 A	4/1958	Hatcher
D189,106 S	10/1960	Leiderman
2,988,191 A	6/1961	Grant
D199,270 S	9/1964	Michaels
D200,216 S	2/1965	Broussard
3,183,411 A	5/1965	Palfi
3,486,324 A	12/1969	Carl-Axel
3,535,870 A	10/1970	Mitchell et al.
3,721,463 A	3/1973	Attwood et al.
3,999,372 A	12/1976	Welch et al.
4,025,791 A	5/1977	Lennington et al.
4,031,991 A	6/1977	Malott
4,043,117 A	8/1977	Maresca et al.
4,310,890 A	1/1982	Trehn et al.
4,460,965 A	7/1984	Trehn et al.
4,812,805 A	3/1989	Lachat et al.
4,823,928 A	4/1989	Speas
4,825,425 A	4/1989	Turner
4,875,598 A	10/1989	Dahl
4,880,097 A	11/1989	Speas
4,895,238 A	1/1990	Speas
D319,077 S	8/1991	Arato et al.
5,065,156 A	* 11/1991	Bernier ..... G07F 17/24 340/309.2
5,155,614 A	10/1992	Carmen et al.
5,201,396 A	4/1993	Chalabian et al.
5,222,076 A	6/1993	Ng et al.
5,244,070 A	9/1993	Carmen et al.
5,273,151 A	12/1993	Carmen et al.
5,360,095 A	11/1994	Speas
5,426,363 A	6/1995	Akagi et al.
5,442,348 A	8/1995	Mushell
5,471,139 A	11/1995	Zadoff
5,563,491 A	10/1996	Tseng

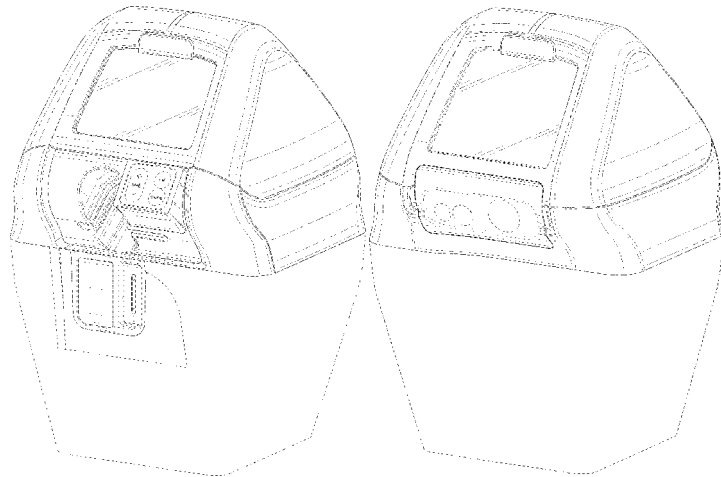

US D959,299 S

5,614,892 A	3/1997	Ward, II et al.	7,783,530 B2	8/2010	Slemmer et al.
5,617,942 A	4/1997	Ward, II et al.	7,825,826 B2	11/2010	Welch et al.
5,640,002 A	6/1997	Ruppert et al.	7,854,310 B2	12/2010	King et al.
5,642,119 A	6/1997	Jacobs	7,855,661 B2	12/2010	Ponert
5,648,906 A	7/1997	Amirpanahi	D635,035 S	3/2011	Matsumoto
5,659,306 A	8/1997	Bahar	7,933,841 B2	4/2011	Schmeyer et al.
D388,231 S	12/1997	Magee et al.	D654,816 S	2/2012	Mackay et al.
5,710,743 A	1/1998	Dee et al.	D656,046 S *	3/2012	MacKay ..... G06Q 20/127
5,732,812 A	3/1998	Grainger et al.			D10/42
D393,212 S	4/1998	Lucas	8,138,950 B1	3/2012	Leung
5,737,710 A	4/1998	Anthonyson	D661,603 S	6/2012	Mackay et al.
5,777,951 A	7/1998	Mitschele et al.	D661,608 S *	6/2012	Kimmich ..... G07F 17/24
5,778,067 A	7/1998	Jones et al.			D10/98
5,805,083 A	9/1998	Sutton et al.	8,279,107 B2	10/2012	Krstanovic et al.
5,806,651 A	9/1998	Carmen et al.	8,325,057 B2 *	12/2012	Salter ..... G01R 21/133
D400,115 S	10/1998	Yaron et al.			705/14.66
5,833,042 A	11/1998	Baitch et al.	8,395,532 B2	3/2013	Chauvin et al.
5,841,369 A	11/1998	Sutton et al.	D683,794 S	6/2013	Randall
5,842,411 A	12/1998	Johnson	D690,771 S	10/2013	Randall
5,845,268 A	12/1998	Moore	D692,784 S	11/2013	Anderssen et al.
5,852,411 A	12/1998	Jacobs et al.	8,590,687 B2	11/2013	King et al.
D412,289 S	7/1999	Winwood	8,595,054 B2 *	11/2013	King ..... G06Q 20/127
5,954,182 A	9/1999	Wei			705/13
5,966,345 A	10/1999	Dee et al.	8,631,921 B2	1/2014	Jones et al.
6,037,880 A	3/2000	Manion	8,684,158 B2	4/2014	Jones et al.
6,078,272 A	6/2000	Jacobs et al.	D705,090 S	5/2014	Mackay et al.
6,081,205 A	6/2000	Williams	D707,140 S	6/2014	King et al.
6,109,418 A	8/2000	Yost	D707,141 S	6/2014	King et al.
6,111,522 A	8/2000	Hiltz et al.	D707,142 S	6/2014	King et al.
6,116,403 A	9/2000	Kiehl	8,770,371 B2	7/2014	Mackay et al.
6,195,015 B1	2/2001	Jacobs et al.	D716,157 S *	10/2014	MacKay ..... D10/42
D439,591 S	3/2001	Reidt et al.	8,862,494 B2	10/2014	King et al.
RE37,193 E	5/2001	Ward, II et al.	8,884,785 B2	11/2014	Groft et al.
6,229,455 B1	5/2001	Yost et al.	9,127,964 B2	9/2015	Schwarz et al.
6,230,868 B1	5/2001	Tuxen et al.	9,169,626 B2 *	10/2015	Guler ..... E03D 5/105
6,243,028 B1	6/2001	Krygler et al.	D749,000 S	2/2016	King et al.
D447,714 S	9/2001	Cappiello	D755,650 S	5/2016	King et al.
D449,010 S	10/2001	Petrucelli	D756,807 S	5/2016	King et al.
6,309,098 B1	10/2001	Wong	D756,808 S	5/2016	King et al.
6,312,152 B2	11/2001	Dee et al.	9,489,776 B2	11/2016	Kell et al.
RE37,531 E	1/2002	Chaco et al.	9,508,198 B1 *	11/2016	King ..... H04Q 9/00
D454,807 S	3/2002	Cappiello	9,652,921 B2 *	5/2017	MacKay ..... G07F 17/24
6,373,422 B1	4/2002	Mostafa	9,661,403 B2	5/2017	King et al.
6,373,442 B1	4/2002	Thomas et al.	D799,992 S	10/2017	Ehara
D461,728 S	8/2002	Tuxen et al.	9,805,518 B2	10/2017	King et al.
6,456,491 B1	9/2002	Flanery et al.	10,299,018 B1 *	5/2019	King ..... H04W 4/80
D463,749 S	10/2002	Petrucelli	D851,605 S	6/2019	Maetani et al.
6,457,586 B2	10/2002	Yasuda et al.	11,100,824 B2 *	8/2021	King ..... G06F 1/1605
6,505,774 B1	1/2003	Fulcher et al.	2001/0012241 A1	8/2001	Dee et al.
6,559,776 B2	5/2003	Katz	2001/0047278 A1	11/2001	Brookner et al.
6,697,730 B2	2/2004	Dickerson	2001/0051531 A1	12/2001	Singhal et al.
6,747,575 B2	6/2004	Chauvin et al.	2002/0008639 A1	1/2002	Dee
D498,795 S	11/2004	Nunn	2002/0111768 A1	8/2002	Ghorayeb et al.
6,812,857 B1	11/2004	Kassab et al.	2003/0092387 A1	5/2003	Hjelmvik
6,856,922 B1	2/2005	Austin et al.	2003/0112151 A1	6/2003	Chauvin et al.
6,874,340 B1	4/2005	Berman	2003/0112597 A1	6/2003	Smith
6,885,311 B2	4/2005	Howard et al.	2003/0121754 A1	7/2003	King
6,889,899 B2	5/2005	Silberberg	2003/0128010 A1	7/2003	Hsu
D506,509 S	6/2005	Nunn	2003/0128136 A1	7/2003	Spier et al.
6,914,411 B2	7/2005	Couch et al.	2003/0132840 A1	7/2003	Bahar
6,929,179 B2	8/2005	Fulcher et al.	2003/0140531 A1	7/2003	Pippins
6,946,974 B1	9/2005	Racunas, Jr.	2003/0144972 A1	7/2003	Cordery et al.
7,019,420 B2	3/2006	Kogan et al.	2003/0169183 A1	9/2003	Korepanov et al.
7,019,670 B2	3/2006	Bahar	2003/0179107 A1	9/2003	Kibria et al.
7,023,360 B2	4/2006	Staniszewski et al.	2003/0220835 A1	11/2003	Barnes et al.
7,027,773 B1	4/2006	McMillin	2003/0222792 A1	12/2003	Berman et al.
7,029,167 B1	4/2006	Mitschele	2004/0068434 A1	4/2004	Kanekon
7,183,999 B2	2/2007	Matthews et al.	2004/0084278 A1	5/2004	Harris et al.
D543,588 S	5/2007	Herbert et al.	2004/0094619 A1	5/2004	Silberberg
7,222,031 B2	5/2007	Heatley	2004/0181496 A1	9/2004	Dinotski et al.
7,237,716 B2	7/2007	Silberberg	2004/0254840 A1	12/2004	Slemmer et al.
7,388,349 B2	6/2008	Elder et al.	2004/0264302 A1	12/2004	Ward
7,391,339 B2	6/2008	Howard et al.	2005/0040951 A1	2/2005	Zalewski et al.
D575,168 S *	8/2008	King ..... H04W 4/80	2005/0099320 A1	5/2005	Nath et al.
		D10/42	2005/0155839 A1	7/2005	Banks et al.
D587,141 S *	2/2009	King ..... E03D 5/105	2005/0178639 A1	8/2005	Brumfield et al.
		D10/42	2005/0192911 A1	9/2005	Mattern
7,748,620 B2	7/2010	Gomez et al.	2005/0226201 A1	10/2005	McMillin et al.
7,772,720 B2	8/2010	McGee et al.	2006/0021848 A1	2/2006	Smith

2006/0116972	A1	6/2006	Wong
2006/0136131	A1	6/2006	Dugan et al.
2006/0149684	A1	7/2006	Matsuura et al.
2006/0152349	A1	7/2006	Ratnakar
2006/0267799	A1	11/2006	Mendelson
2007/0016539	A1	1/2007	Groft et al.
2007/0040449	A1	2/2007	Spurlin et al.
2007/0074702	A1	4/2007	Nakamura et al.
2007/0094153	A1	4/2007	Ferraro
2007/0114849	A1	5/2007	Falik et al.
2007/0119682	A1	5/2007	Banks et al.
2007/0136128	A1	6/2007	Janacek et al.
2007/0184852	A1	8/2007	Johnson et al.
2007/0189907	A1	8/2007	Kunihiro et al.
2007/0210935	A1	9/2007	Yost et al.
2007/0285281	A1	12/2007	Welch
2008/0052254	A1	2/2008	Al Amri et al.
2008/0071611	A1	3/2008	Lovett
2008/0093454	A1	4/2008	Yamazaki et al.
2008/0147268	A1	6/2008	Fuller
2008/0208680	A1	8/2008	Cho
2008/0238715	A1	10/2008	Cheng et al.
2008/0245638	A1	10/2008	King et al.
2008/0270227	A1	10/2008	Al Amri
2009/0026842	A1	1/2009	Hunter et al.
2009/0032368	A1	2/2009	Hunter et al.
2009/0095593	A1	4/2009	King et al.
2009/0109062	A1	4/2009	An
2009/0159674	A1	6/2009	King et al.
2009/0183966	A1	7/2009	King et al.
2009/0192950	A1	7/2009	King et al.
2009/0267732	A1	10/2009	Chauvin et al.
2009/0284907	A1	11/2009	Regimbal et al.
2009/0315720	A1	12/2009	Clement et al.
2010/0106517	A1	4/2010	Kociubinski et al.
2010/0188932	A1	7/2010	Hanks et al.
2010/0332394	A1	12/2010	Ioli
2011/0057815	A1	3/2011	King et al.
2011/0060653	A1	3/2011	King et al.
2011/0063133	A1	3/2011	Keller et al.
2011/0203901	A1	8/2011	King et al.
2011/0313822	A1	12/2011	Burdick
2011/0320243	A1	12/2011	Khan
2012/0084210	A1	4/2012	Farahmand
2012/0158466	A1	6/2012	John
2012/0222935	A1	9/2012	Mackay et al.
2012/0285790	A1	11/2012	Jones et al.
2012/0285791	A1	11/2012	Jones et al.
2012/0285792	A1	11/2012	Jones et al.
2012/0285793	A1	11/2012	Jones et al.
2012/0286036	A1	11/2012	Jones et al.
2012/0292385	A1	11/2012	Mackay et al.
2013/0005445	A1	1/2013	Walker et al.
2013/0027218	A1	1/2013	Schwarz et al.
2013/0099943	A1	4/2013	Subramanya
2013/0116952	A1	5/2013	Chai
2013/0238406	A1	9/2013	King et al.
2014/0108107	A1	4/2014	Jones et al.
2014/0129158	A1	5/2014	Shea
2014/0174881	A1	6/2014	King et al.
2014/0210646	A1	7/2014	Subramanya
2014/0214499	A1	7/2014	Hudson et al.
2014/0214500	A1	7/2014	Hudson et al.
2014/0229246	A1	8/2014	Ghaffari
2015/0106172	A1	4/2015	Salama
2015/0129391	A1	5/2015	Jones et al.
2015/0332587	A1	11/2015	Schwarz et al.
2017/0098339	A1	4/2017	Keller et al.
2018/0025549	A1	1/2018	King et al.
2018/0225909	A1	8/2018	Mackay et al.
2019/0131819	A1	5/2019	Bell

FOREIGN PATENT DOCUMENTS

CA	2377010	A1	10/2001
CA	2363915	A1	5/2003
EP	0329129	A2	8/1989
EP	0980055	B1	9/2001
EP	1128350	B1	10/2007

FR	2837583	A1	9/2003
IL	149880	A	6/2007
JP	S5259000	A	5/1977
JP	S58121494	A	7/1983
JP	2002042181	A	2/2002
JP	2002099640	A	4/2002
JP	2005267430	A	9/2005
KR	20050038077	A	4/2005
W●	W●-2005031494	A2	4/2005
W●	W●-2006095352	A2	9/2006
W●	W●-2009154787	A2	12/2009
W●	W●-2014014494	A1	1/2014

OTHER PUBLICATIONS

Cell Net Data Systems. First Wireless Monitoring of Parking Meters Results in Theft Arrests Using CellNet Data Systems Technology. PRNewswire (May 11, 1999) (2 pgs.).  
 City of Culver City. CA Agenda Item Report. Approval of a Contract with IPS Group Inc., for the Sole-Source Purchase of 1,000 Parking Meters. (3 pgs.) (Dec. 12, 2011).  
 Co-pending U.S. Appl. No. 29/680,837, inventors King; David William et al., filed Feb. 20, 2019.  
 Co-pending U.S. Appl. No. 29/759,012, inventors Jones; David Andrew et al., filed Nov. 19, 2020.  
 Co-pending U.S. Appl. No. 29/759,014, inventors Jones; David Andrew et al., filed Nov. 19, 2020.  
 Co-pending U.S. Appl. No. 29/759,016, inventors Jones; David Andrew et al., filed Nov. 19, 2020.  
 Co-pending U.S. Appl. No. 29/759,019, inventors Jones; David Andrew et al., filed Nov. 19, 2020.  
 Fidelman. Time's Running Out for Parking Meters at Present Locations: \$270,000 Cited as Replacement Cost. City Employees Who Ticket Motorists Find Electronic Meters Unsuitable. The Gazette, Final Edition, Montreal, Quebec, Canada, Nov. 12, 2002, p. A7.  
 Flatley. In San Francisco, Hackers Park for Free. Read filed under Mise. Gadgets, downloaded from www.engadget.com website on May 3, 2010. Originally posted on Jul. 31, 2009 (5 pgs.).  
 Howland. How M2M Maximizes Denver's Revenue. Field TechnologiesOnline.com, Oct. 2011, pp. 9-12 [online] [retrieved Mar. 5, 2013], Retrieved from http://www.fieldtechnologiesonline.com/doc.mvc/How-M2M-Maximizes-Denvers-Revenue-0001 (4 pgs.).  
 Jim Bonfield. An Exercise in Changing The Business: Advertising Vending Machines. (4 pgs.) (Feb. 7, 2018).  
 Meter Solutions, Single-Space Meters brochure, downloaded from www.duncansolutions.com website, (revised Apr. 2006) (2 pgs.).  
 Sedadi. Card & Coin Parking Meter Lease. City of Los Angeles Inter-Departmental Correspondence. (4 pgs.) (Nov. 29, 2010).  
 Spyker et al. Predicting Capacitor Run Time For a Battery/Capacitor Hybrid Source. Power Electronic Drives and Energy Systems for Industrial Growth. 1998. Proceedings. 1998 IEEE International Conference, pp. 809-814.  
 The U.S. Conference of Mayors Presents 'Best Practice' Awards, Los Angeles, New Orleans, Elizabeth, N.J. and Long Beach, CA Honored for Excellence & Innovation in Public-Private partnerships, Press Release Jan. 20, 2012 (3 pgs.).  
 Transportation Commission Staff Report. Alternate Downtown Parking Pay Technology. Agenda Item No. 5.b (4 pgs.) (Oct. 20, 2011).  
 Tung. Design of an advanced on-street parking meter. RIT Scholar Works. Thesis/Dissertation Collections (75 pgs.) (2001).

\* cited by examiner

Primary Examiner — Antoine Duval Davis  
 (74) Attorney, Agent, or Firm — Wilson Sonsini Goodrich & Rosati

(57) CLAIM

The ornamental design for a meter cover, as shown and described.

DESCRIPTION

FIG. 1 is a top, front, right perspective view of a meter cover, showing our new design;

FIG. 2 is a top, back, left perspective view thereof;  
FIG. 3 is a back elevational view thereof;  
FIG. 4 is a front elevational view thereof;  
FIG. 5 is a top plan view thereof;  
FIG. 6 is a right side elevational view thereof; and,  
FIG. 7 is a left side elevational view thereof.  
The broken line showing of environmental matter is for illustrative purposes only and forms no part of the claimed design.

**1 Claim, 7 Drawing Sheets**

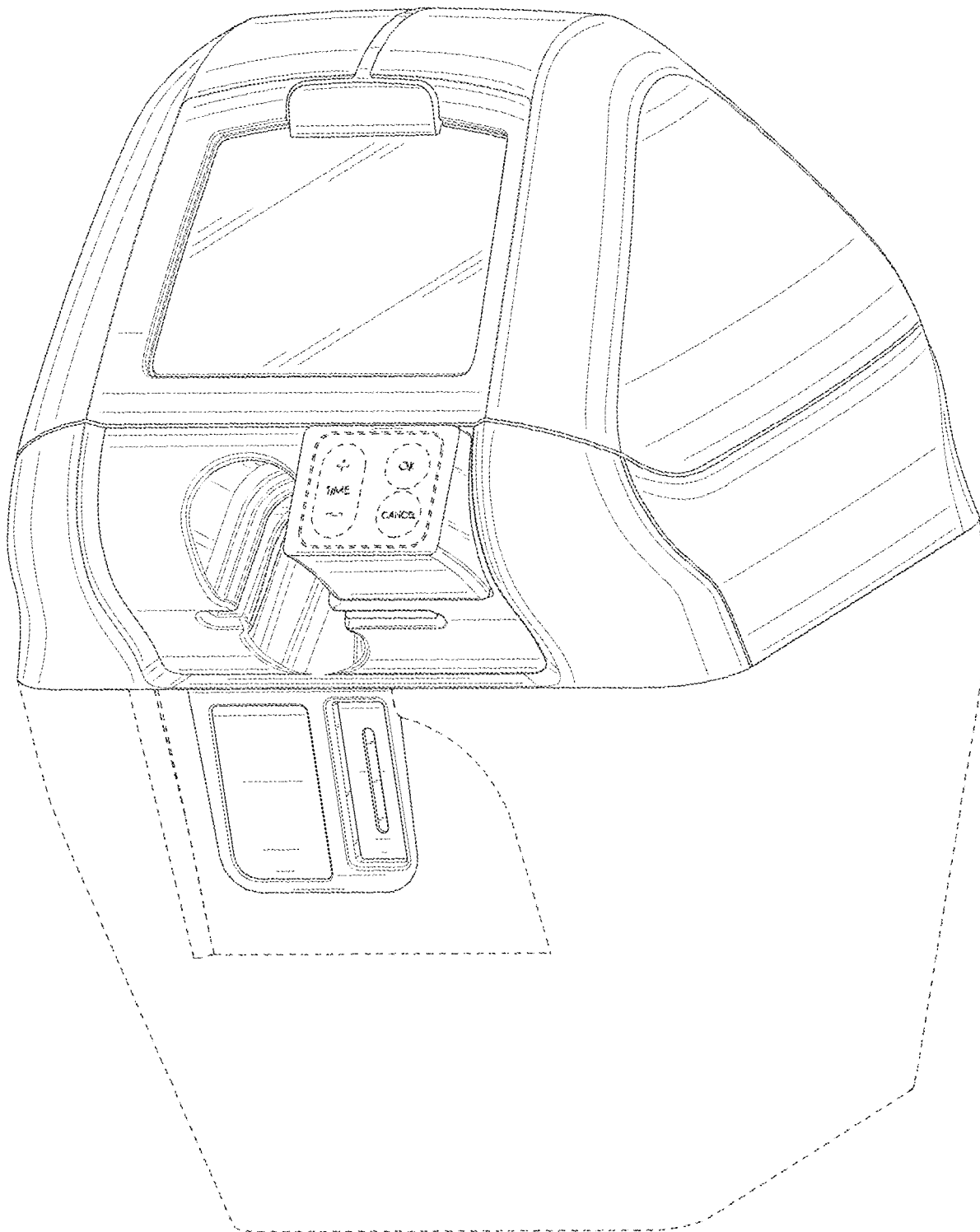

FIG. 1

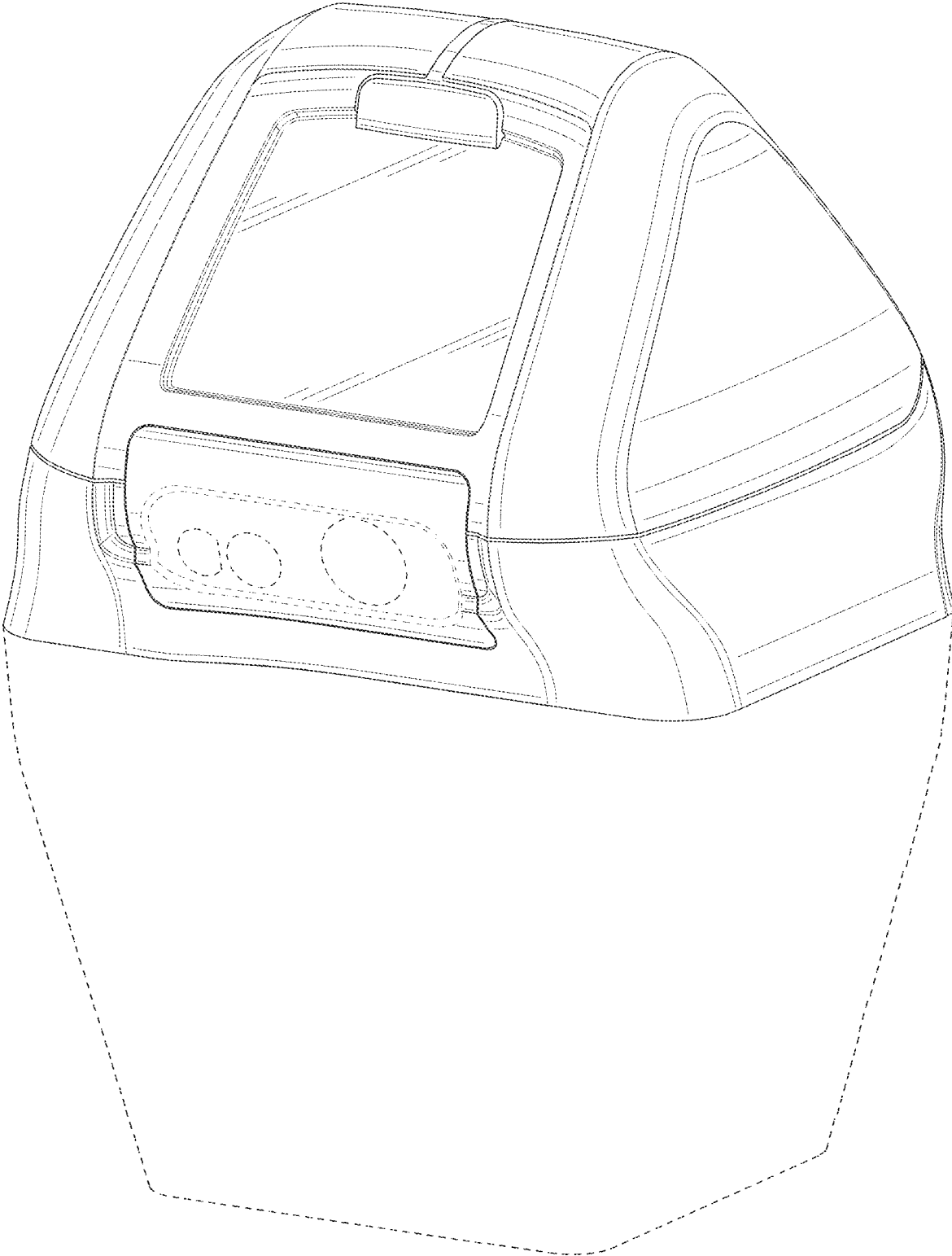

FIG. 2

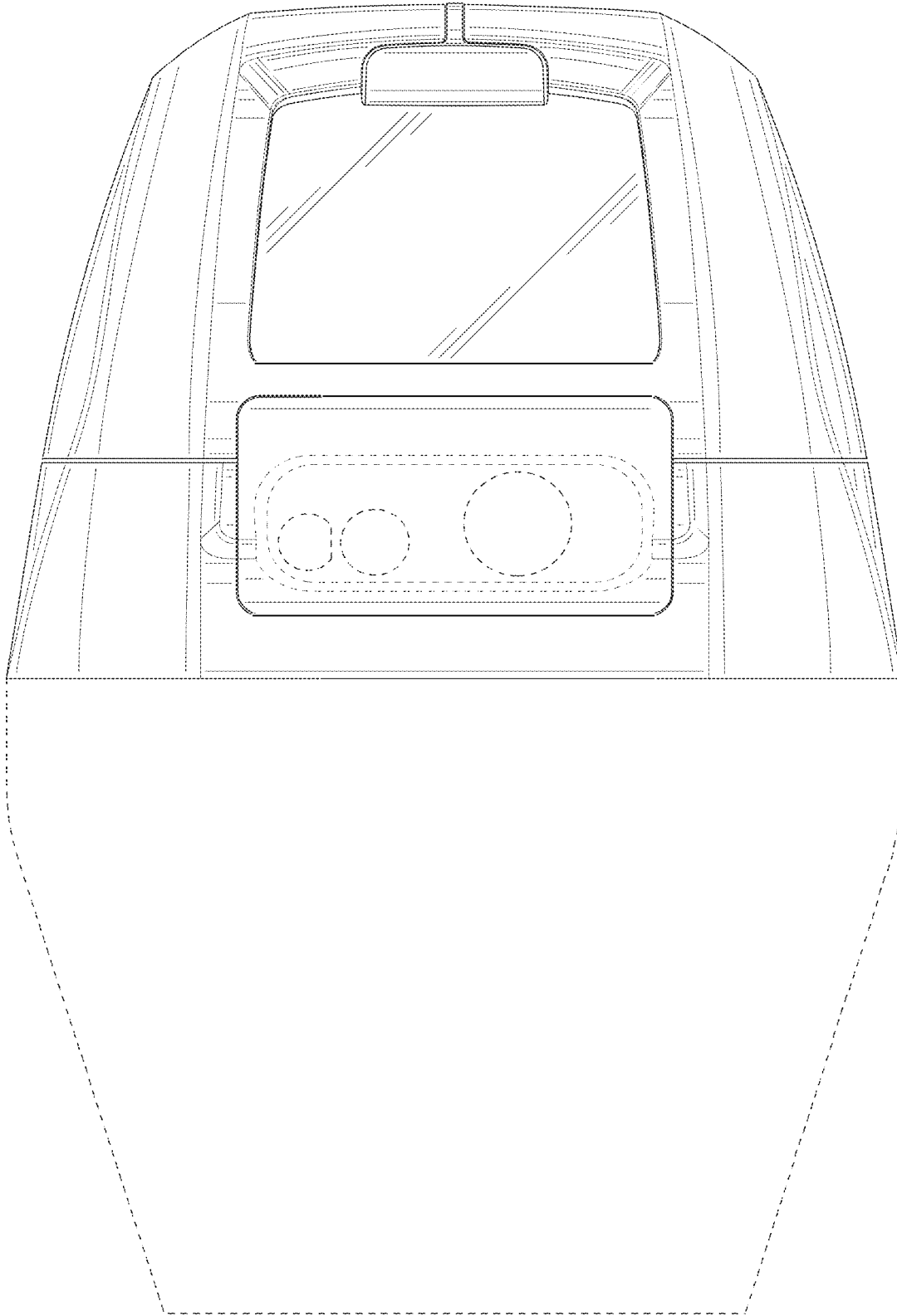

FIG. 3

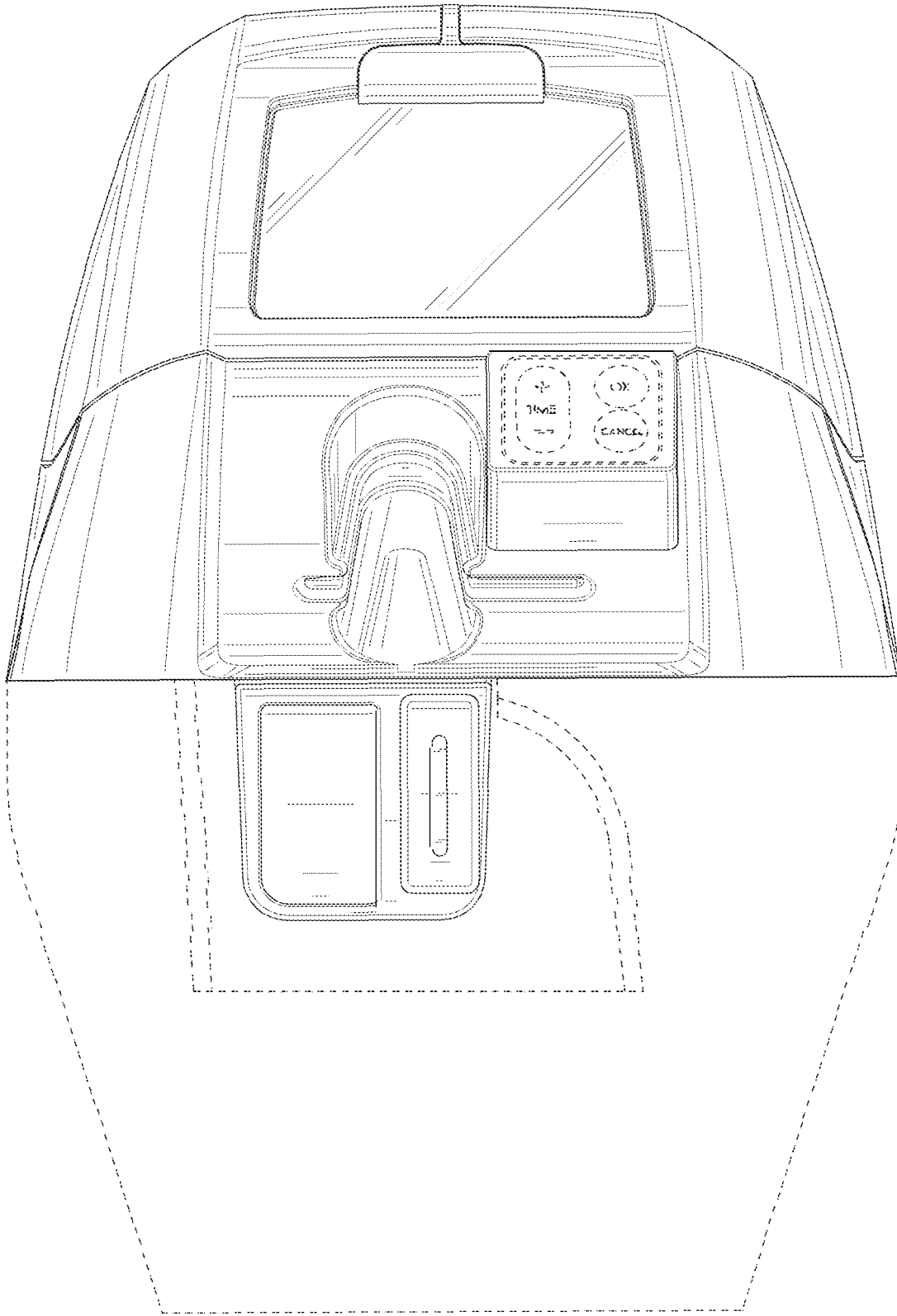

FIG. 4



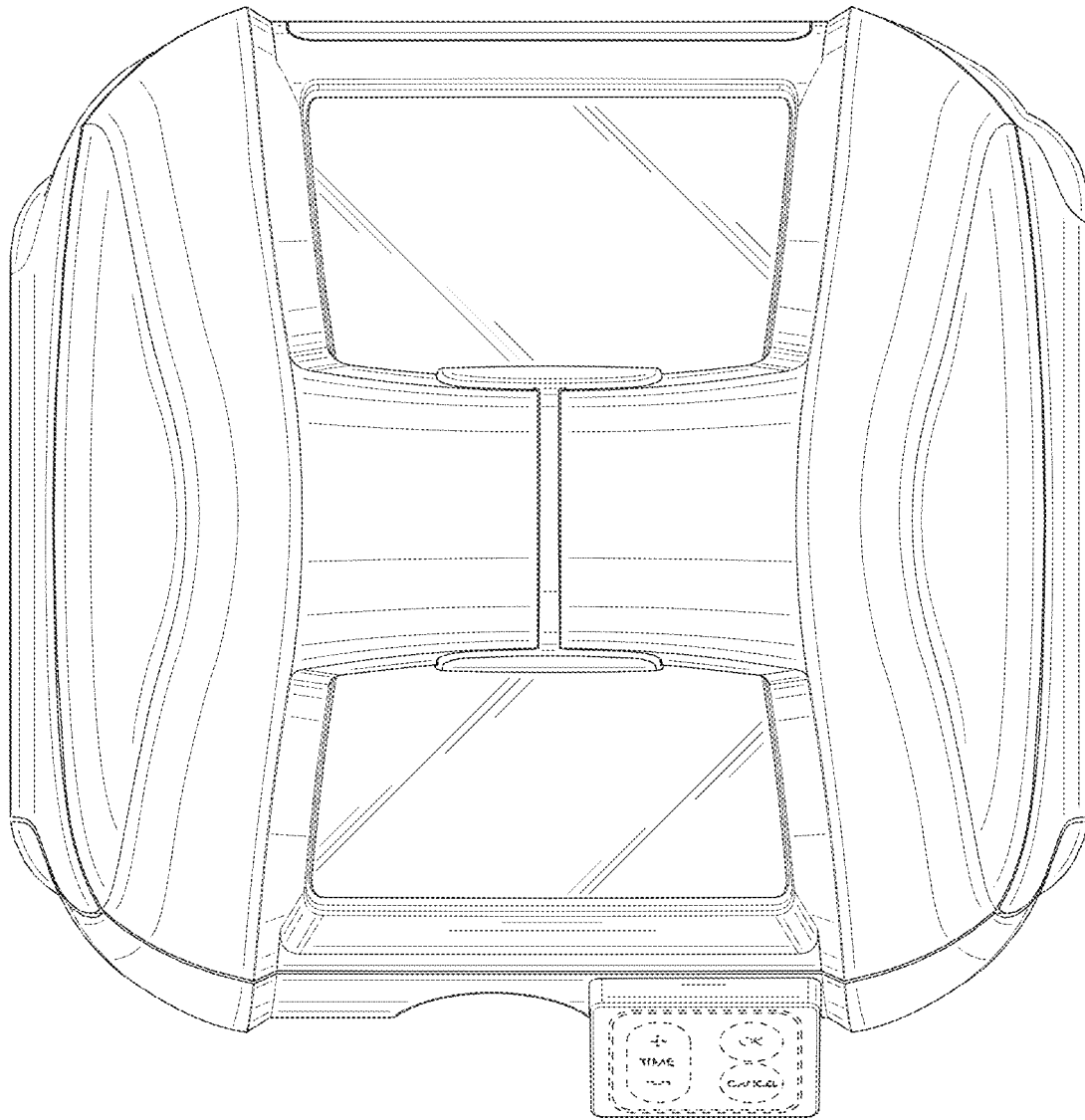

FIG. 5

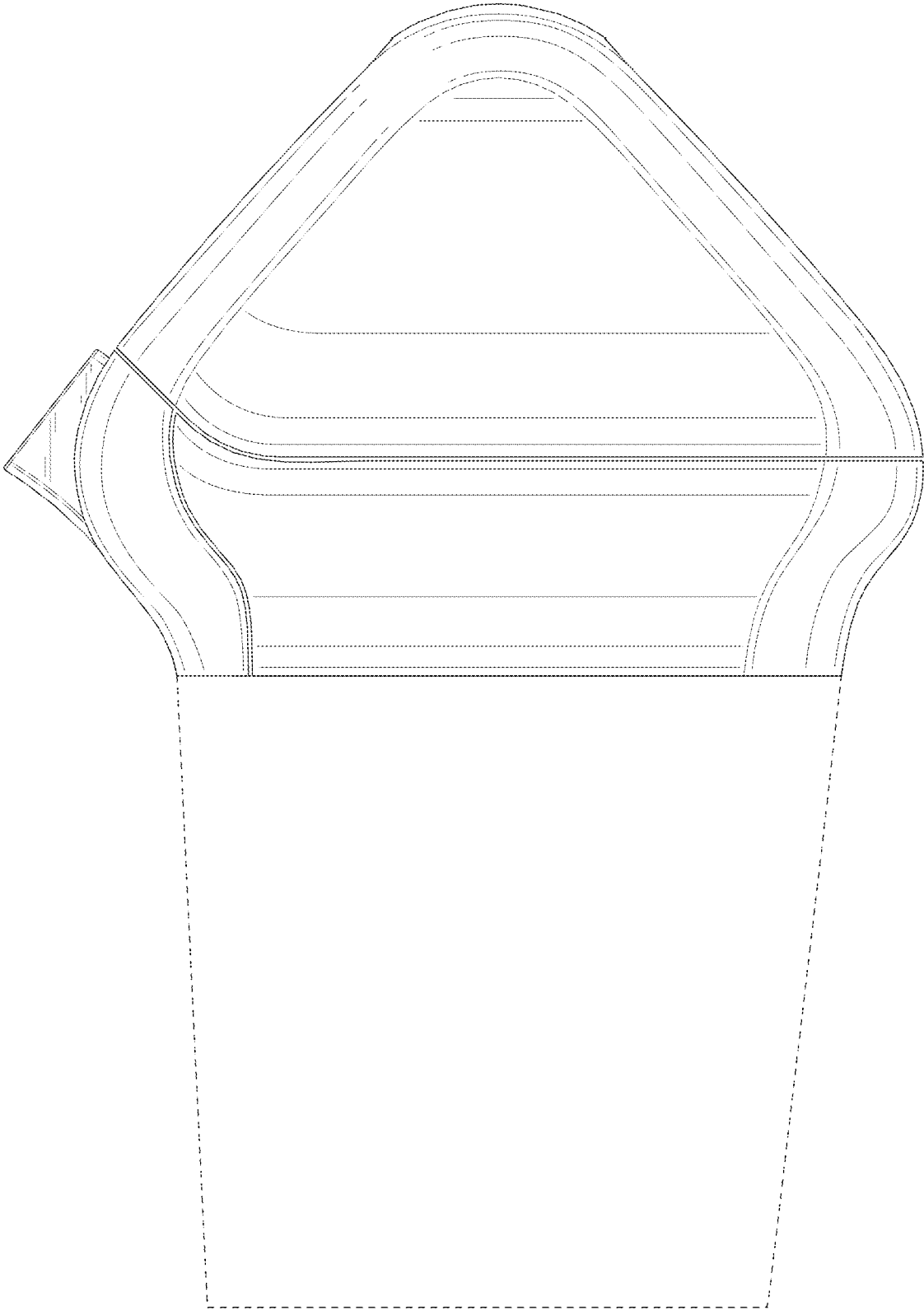

FIG. 6

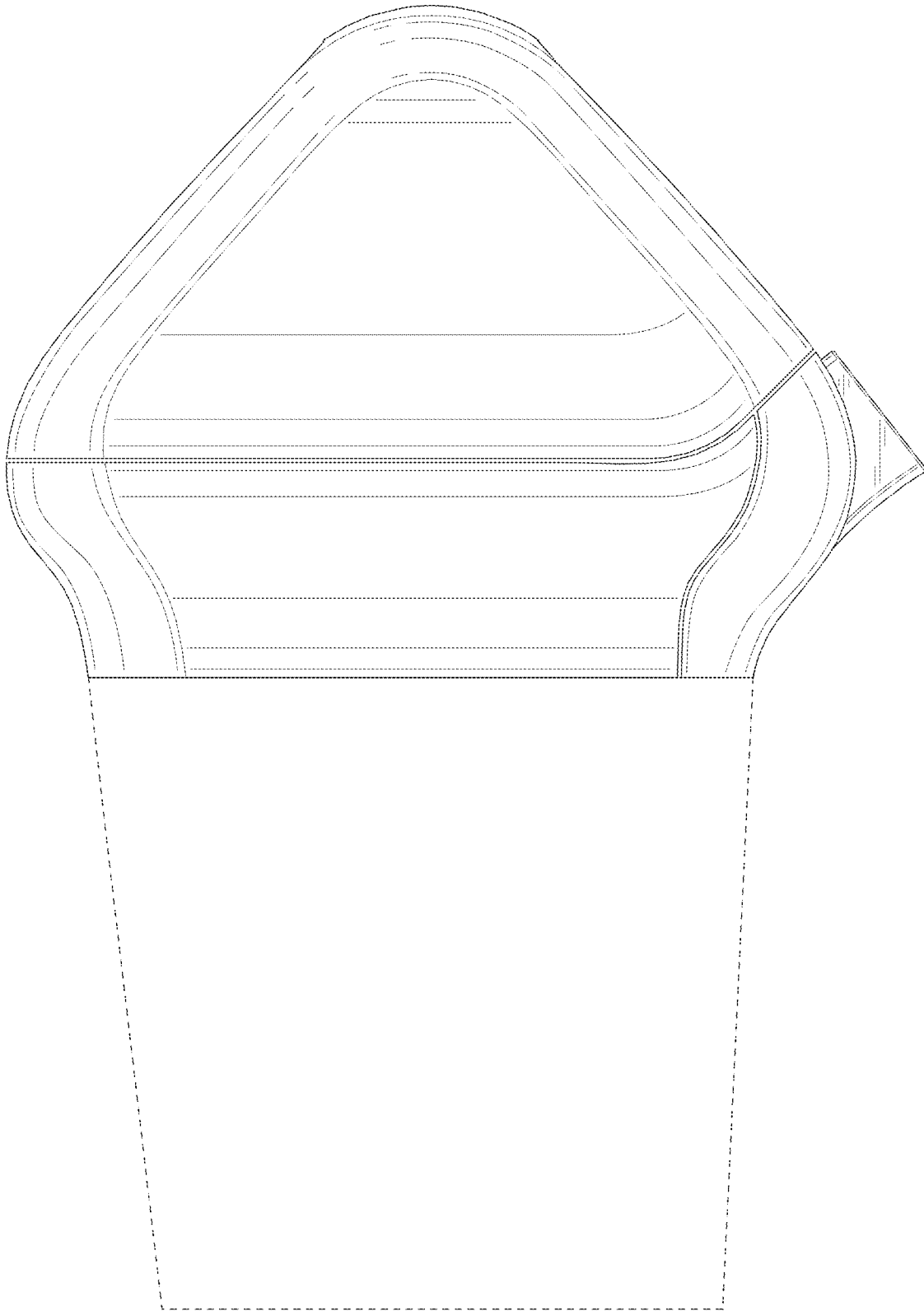

FIG. 7