



Office de la Propriété
Intellectuelle
du Canada
Un organisme
d'Industrie Canada

Canadian
Intellectual Property
Office
An agency of
Industry Canada

Registration Number:
Date of Registration:

156995
2015-05-26

MULTISPACE PARKING PAY STATION

Applicant(s) as Filed: **IPS Group, Inc.**

Description:

The Design consists of the features of shape, configuration, and ornament of the MULTISPACE PARKING PAY STATION as shown in solid lines in the drawings. Portions shown in stippled lines do not form part of the design. Drawings of the Design are included, in which: Figure 1 is a top front perspective view of a MULTISPACE PARKING PAY STATION; Figure 2 is a front elevational view thereof; Figure 3 is a left side elevational view thereof; Figure 4 is a right side elevational view thereof; Figure 5 is a top plan view thereof; and Figure 6 is a bottom plan view thereof.

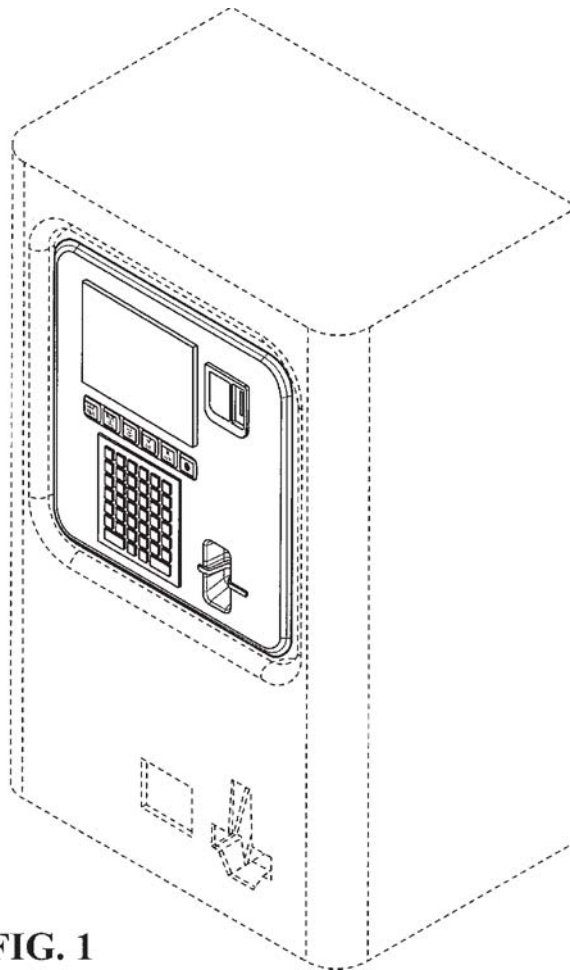

FIG. 1

Details

Third-Party Information Liability Disclaimer

Some of the information on this Web page has been provided by external sources. The Government of Canada is not responsible for the accuracy, reliability or currency of the information supplied by external sources. Users wishing to rely upon this information should consult directly with the source of the information. Content provided by external sources is not subject to official languages, privacy and accessibility requirements.

National Application/Registration : 156995

Date of Registration :

2015-05-26

Made available on :

2015-05-26

Status :

Registered

Title or finished article: MULTISPACE PARKING PAY STATION

Canadian Classification:

10-03-OTHER TIME-MEASURING INSTRUMENTS

Other Classes Searched:

N/A

Description:

The Design consists of the features of shape, configuration, and ornament of the MULTISPACE PARKING PAY STATION as shown in solid lines in the drawings. Portions shown in stippled lines do not form part of the design. Drawings of the Design are included, in which: Figure 1 is a top front perspective view of a MULTISPACE PARKING PAY STATION; Figure 2 is a front elevational view thereof; Figure 3 is a left side elevational view thereof; Figure 4 is a right side elevational view thereof; Figure 5 is a top plan view thereof; and Figure 6 is a bottom plan view thereof.

Statement:

N/A

Interested Parties

Applicant(s) as Filed:

IPS GROUP, INC.

Registered Proprietor(s):

IPS GROUP, INC.
5601 OBERLIN DRIVE, SUITE 100
SAN DIEGO, 92121
CALIFORNIA, UNITED STATES OF AMERICA

Proprietor(s):

IPS GROUP INC.
7737 KENAMAR COURT
SAN DIEGO, 92121
CALIFORNIA, UNITED STATES OF AMERICA

Client Reference Number:

83472-29

Representative for Service:

SMART & BIGGAR LLP
2300-1055 WEST GEORGIA BOX 11115
VANCOUVER, V6E 3P3
BRITISH COLUMBIA, CANADA

Agent:

SMART & BIGGAR LLP
2300-1055 WEST GEORGIA BOX 11115
VANCOUVER, V6E 3P3
BRITISH COLUMBIA, CANADA

Registration Expiry date (Subject to payment of a maintenance fee): 10 years

Maintenance Fee Paid:

Yes

Filing Date:

2014-06-05

Correction(s):

No

Priority Claim(s):

Third-Party Information Liability Disclaimer

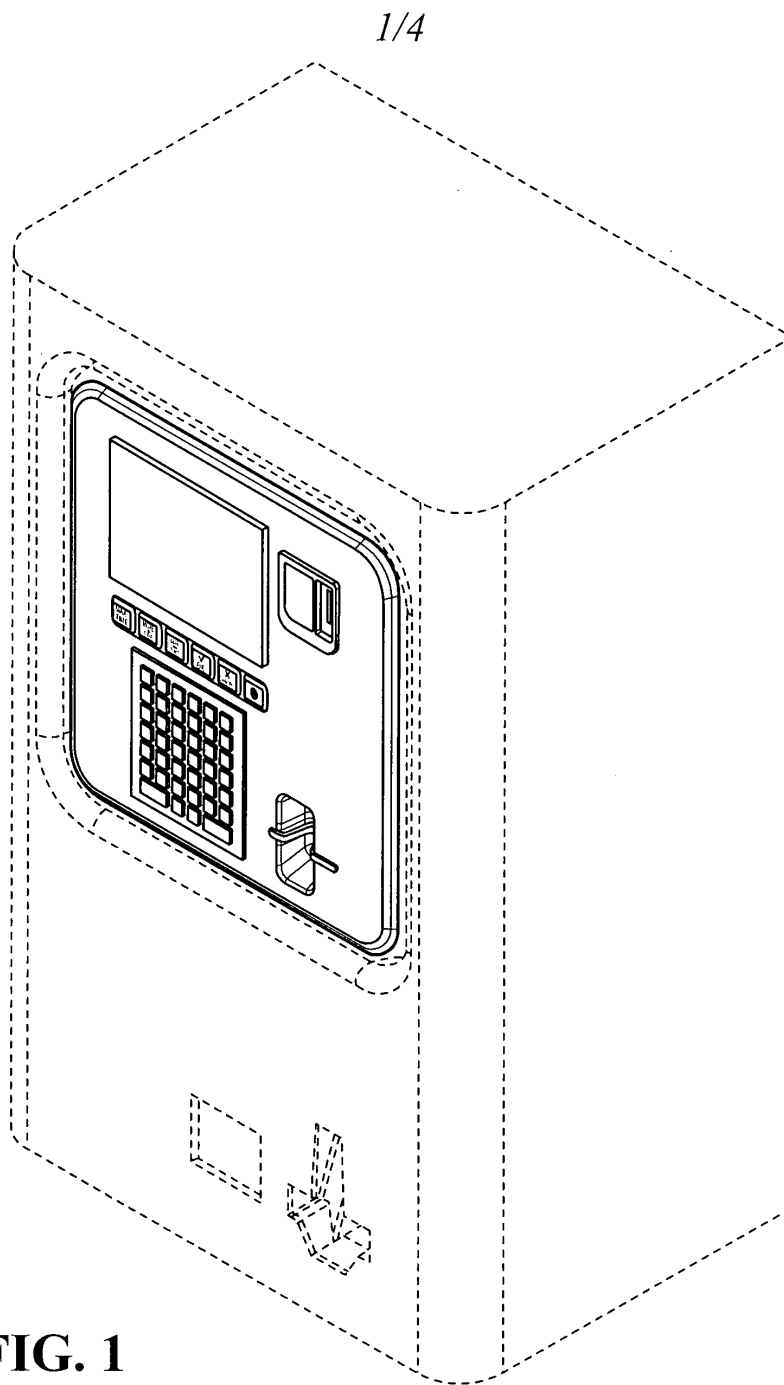

FIG. 1

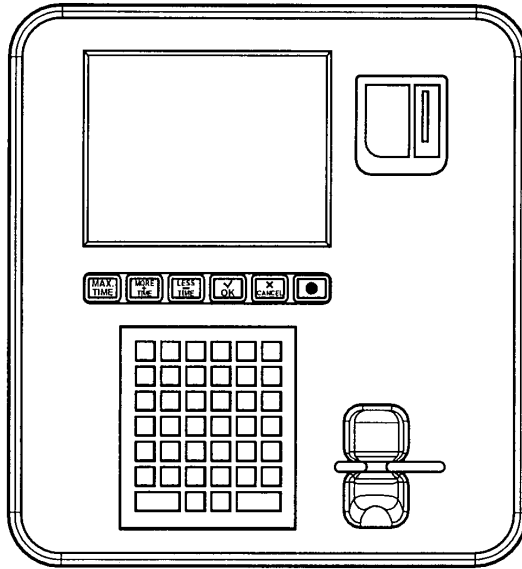

FIG. 2

3/4



FIG. 3



FIG. 4

4/4



FIG. 5



FIG. 6